

# OPTIMIZING DISTRICT COOLING PERFORMANCE UTILIZING ICE SLURRY

By Kirby P. Nelson, P.E.  
Paul Mueller Company • Springfield, Missouri

Presented at the IDEA Conference • Williamsburg, Virginia  
October, 1998 • Used with permission.

## ABSTRACT

The purpose of this paper is to provide an understanding of the operational dynamics of an ice slurry system as applied against an assumed load of 341,000 ton-hours per day and a peak load of 25,000 tons. The paper illustrates two characteristics of ice slurry that may be important to district cooling projects:

- (1) 30°F system supply temperature can be provided.
- (2) Flexibility in design, and therefore the ability to grow a district cooling system to the final phase in the most cost-effective manner.

## KEY WORDS

- Ice Slurry
- District Cooling
- Ice Thermal Storage
- Thermal Storage

## INTRODUCTION

An ice slurry generator (ISG) has two characteristics which will be discussed in this paper:

- (1) **30°F Supply Water** —The ice slurry generator requires a freeze depressant for ice production; therefore, the ice is made at solution temperatures of about 27°F, down to about 24°F. The result is that 30°F temperature is possible from the ice slurry storage tank. Reference Two makes the point that 34°F system supply temperature provides several operating and cost savings advantages. An ice slurry system can provide 30°F system supply temperature, thus it offers additional savings in the distribution system and equipment costs. This additional 4°F drop in system supply temperature requires additional ice melting to meet the load; which, in turn, requires additional ice slurry generator capacity and storage. Therefore, the comparison of first cost and operating cost of an ice slurry system versus ice-on-coil system is a rather complex issue.
- (2) **System Flexibility** —The ice slurry generator system provides flexibility in design. As a system grows from Phase I to Final Phase, the combination of centrifugal chillers and ice machines can be optimized for the given load.

The Final Phase cooling loads of a project may be significantly different than originally planned. If so, the flexibility of an Ice Slurry System could prove to be very cost effective.

These two (ISG) characteristics will be evaluated via a math model that has been verified by equipment data and test results.

# MATH MODEL

The math model is based on the following:

- Centrifugal Chiller Capacity = 1,915 Tons
- Screw Chiller Capacity = 2,555 Tons
- Screw Machine Ice Capacity = 1,920 Tons

The model includes the characteristics of the ice slurry generator and the chiller performance characteristics. The system supply water temperature is 30°F.

The distribution system flow is based on water, and therefore the flow may change ± 1 to 2% depending on the freeze depressant chosen for a given project.

**Figure 1 - Basic System**

The figure illustrates the basic system to be modeled. The chiller loop is decoupled from the distribution loop.

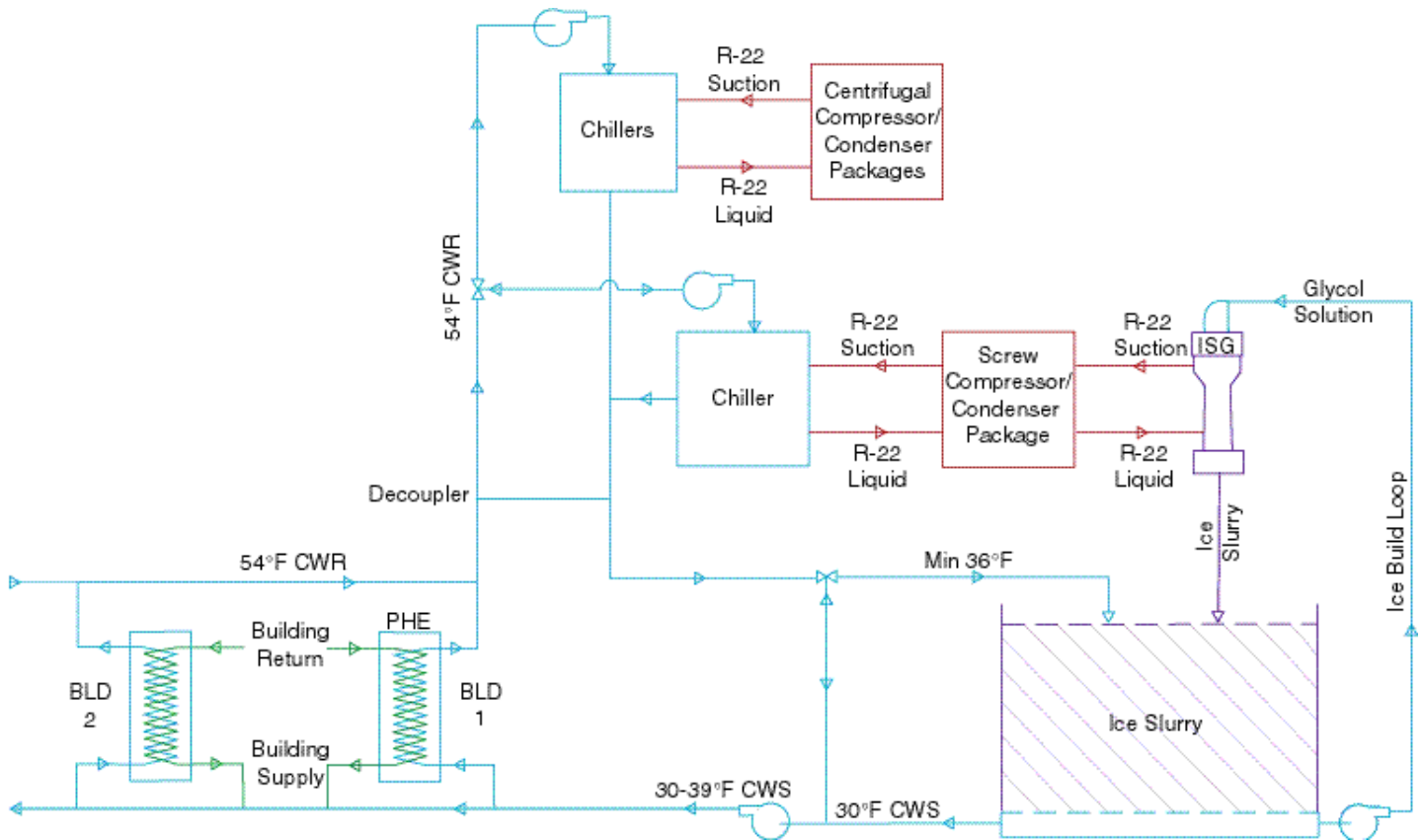

The following systems will be modeled:

System	Number of Centrifugals	Number of Screws
1	4	4
2	5	3
3	3	1
4	3	2
5	8	2
6	6	3

**Chart 1 - System Requirements**

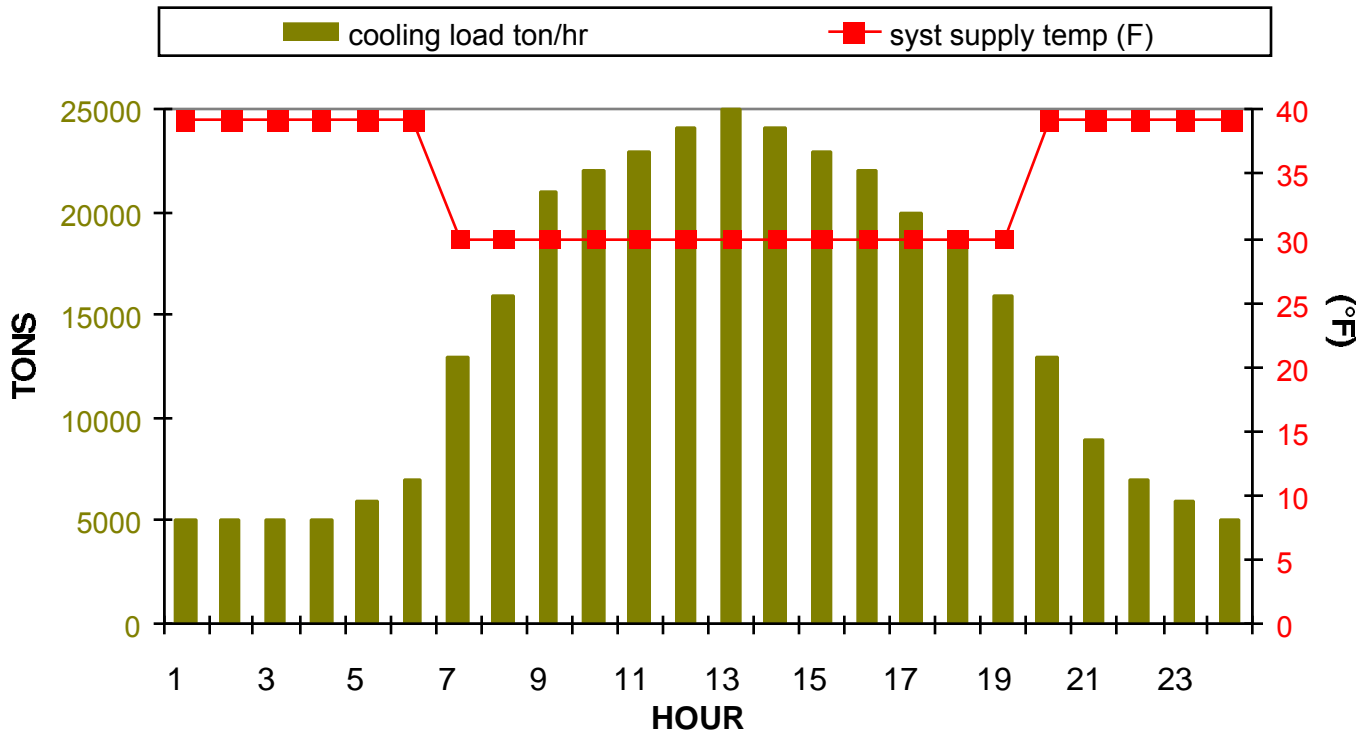

## SYSTEM ONE

Providing 30°F supply temperature requires additional ice when compared to a 34°F system. However, the equipment required is not significantly more than for a typical 34°F system as illustrated by the analysis below. This analysis consists of four ice screw machines of over 7,000 tons of ice slurry generating capacity and 4 x 2,555 = 10,220 plus 1,915 x 4 = 17,880 tons of chilling capacity to meet the 25,000 peak ton load. A storage tank of 77,000 ton-hours is required and ice provides a peak of 7,777 tons or 31% of the 25,000 tons peak.

**Table 1 - System One**

### ICE SLURRY—4 ICE MACHINES—4 CENTRIFUGAL—100% LOAD

End of Hour	Cooling Load ton/hr (100%)	System Supply Temp (°F)	Distribution System Chw Flow (gpm)	Centrifugal Water Chillers Operating	Screw Water Chillers Operating	Chiller Leaving Temp (°F)	Chiller Enter Temp (°F)	Water Chiller Capacity (tons)	Hourly Ice Melt (tons)	Number Compressors Making Ice	Hourly Ice Build (tons)	Storage Tank (ton/hr)
1	5000	39	8000	3	0	39.00	51.16	5000	0	4	7468	39,861
2	5000	39	8000	3	0	39.00	51.16	5000	0	4	7419	47,280
3	5000	39	8000	3	0	39.00	51.16	5000	0	4	7371	54,651
4	5000	39	8000	3	0	39.00	51.16	5000	0	4	7322	61,973
5	6000	39	9600	4	0	39.00	49.94	6000	0	4	7274	69,247
6	7000	39	11,200	4	0	39.00	51.77	7000	0	4	7227	76,474
7	13,000	30	13,000	4	1	36.19	49.38	9649	3350	0	0	73,124
8	16,000	30	16,000	4	2	35.97	49.12	12,022	3977	0	0	69,148
9	21,000	30	21,000	4	3	37.20	50.60	14,700	6298	0	0	62,850
10	22,000	30	22,000	4	3	37.82	51.34	14,836	7162	0	0	55,688
11	23,000	30	23,000	4	4	36.34	49.56	16,928	6070	0	0	49,618
12	24,000	30	24,000	4	4	36.92	50.26	17,078	6919	0	0	42,699
13	25,000	30	25,000	4	4	37.47	50.92	17,220	7777	0	0	34,922
14	24,000	30	24,000	4	4	36.92	50.26	17,078	6919	0	0	28,003
15	23,000	30	23,000	4	4	36.34	49.56	16,928	6070	0	0	21,933
16	22,000	30	22,000	4	3	37.82	51.34	14,836	7162	0	0	14,772
17	20,000	30	20,000	4	3	36.54	49.80	14,553	5445	0	0	9327
18	19,000	30	19,000	4	3	35.82	48.94	14,394	4604	0	0	4723
19	16,000	30	16,000	4	2	35.97	49.12	12,022	3977	0	0	400
20	13,000	39	20,800	4	1	42.21	54.00	10,215	2784	3	5758	3374
21	9000	39	14,400	4	0	41.23	54.00	7660	1339	4	7658	9693
22	7000	39	11,200	4	0	39.00	51.77	7000	0	4	7617	17,309
23	6000	39	9600	4	0	39.00	49.94	6000	0	4	7567	24,876
24	5000	39	8000	3	0	39.00	51.16	5000	0	4	7517	32,393
TOT	341,000				41			261,117	79,851	43	80,197	

**Chart 2 - System One**

**4 Ice Machines—4 Centrifugals**

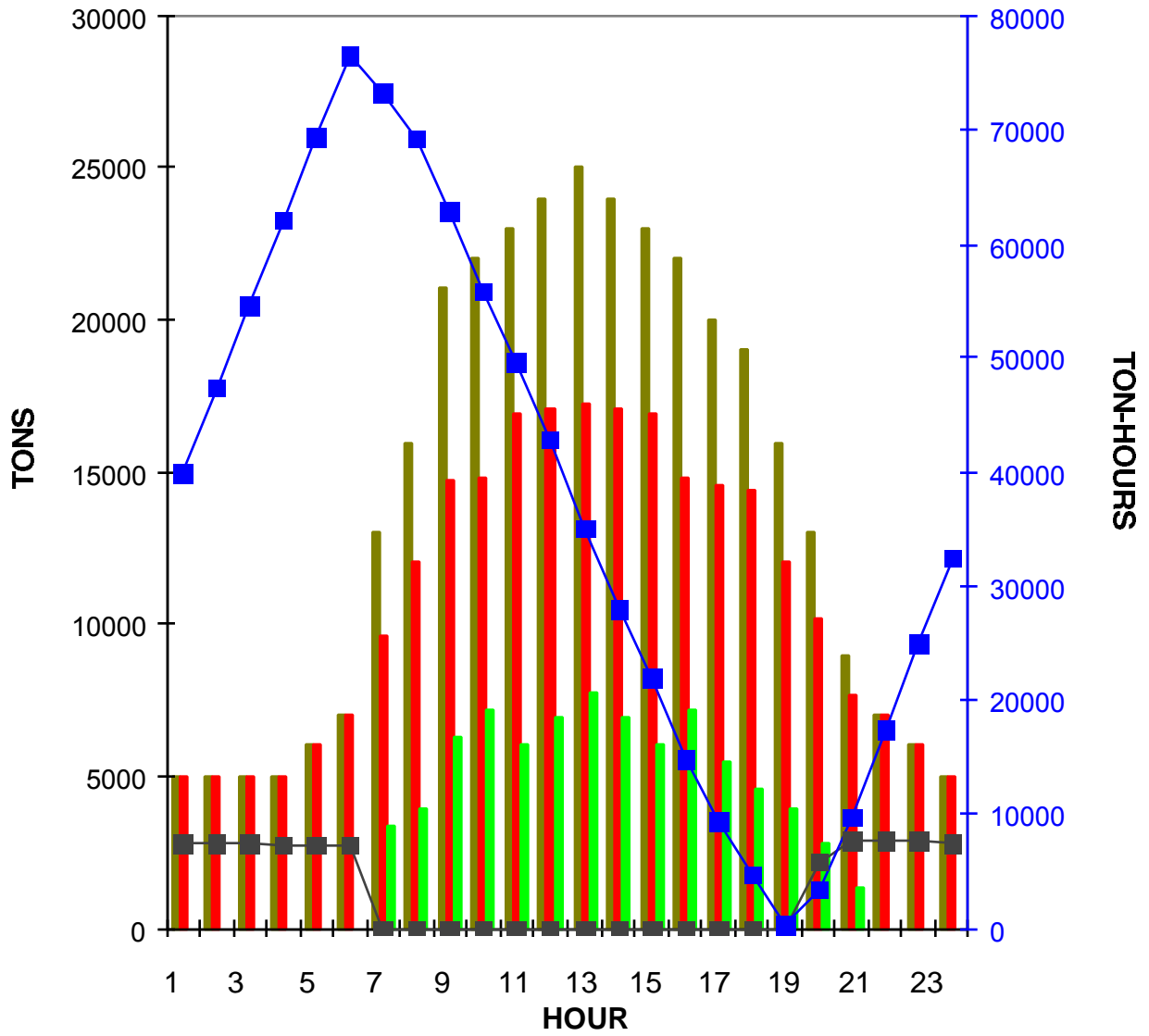
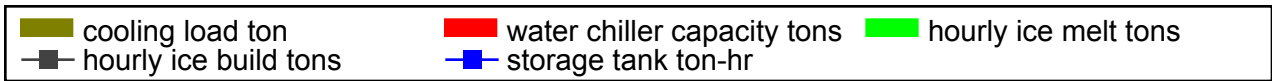

## SYSTEM TWO

In general, the cost of centrifugal equipment will be less than screw machines. Therefore, the most cost-effective system is probably the system with the least ice screw machines that will provide 30°F system supply temperature. This system has an ice generating capacity of about 5,600 tons provided by three ice screw machines. Chilling capacity is  $3 \times 2,555 = 7,665$  tons plus  $5 \times 1,915 = 17,240$  tons which is a little less than System One. A 62,000 ton-hour slurry ice storage tank is required and ice provides a peak of 8,275 tons or 33% of the 25,000-ton peak load.

**Table 2 - System Two**

### ICE SLURRY—3 ICE MACHINES—5 CENTRIFUGAL—100% LOAD

End of Hour	Cooling Load ton/hr (100%)	System Supply Temp (°F)	Distribution System Chw Flow (gpm)	Centrifugal Water Chillers Operating	Screw Water Chillers Operating	Chiller Leaving Temp (°F)	Chiller Enter Temp (°F)	Water Chiller Capacity (tons)	Hourly Ice Melt (tons)	Number Compressors Making Ice	Hourly Ice Build (tons)	Storage Tank (ton/hr)
1	5000	39	8000	3	0	39.00	51.16	5000	0	3	5628	32,460
2	5000	39	8000	3	0	39.00	51.16	5000	0	3	5601	38,060
3	5000	39	8000	3	0	39.00	51.16	5000	0	3	5573	43,634
4	5000	39	8000	3	0	39.00	51.16	5000	0	3	5546	49,179
5	6000	39	9600	4	0	39.00	49.94	6000	0	3	5519	54,698
6	7000	39	11,200	4	0	39.00	51.77	7000	0	3	5491	60,189
7	13,000	30	13,000	5	0	37.08	50.45	9167	3831	3	5465	61,823
8	16,000	30	16,000	5	1	36.68	49.98	11,545	4454	2	3638	61,007
9	21,000	30	21,000	5	2	37.77	51.28	14,205	6792	1	1820	56,035
10	22,000	30	22,000	5	2	38.36	52.00	14,332	7665	1	1828	50,199
11	23,000	30	23,000	5	3	36.84	50.16	16,446	6551	0	0	43,648
12	24,000	30	24,000	5	3	37.41	50.85	16,589	7408	0	0	36,240
13	25,000	30	25,000	5	3	37.95	51.50	16,722	8275	0	0	27,965
14	24,000	30	24,000	5	3	37.41	50.85	16,589	7408	0	0	20,557
15	23,000	30	23,000	5	3	36.84	50.16	16,446	6551	0	0	14,006
16	22,000	30	22,000	5	2	38.36	52.00	14,332	7665	1	1897	8238
17	20,000	30	20,000	5	2	37.12	50.50	14,068	5929	1	1907	4215
18	19,000	30	19,000	5	2	36.42	49.66	13,920	5078	1	1913	1050
19	16,000	30	16,000	5	1	36.68	49.98	11,545	4454	2	3837	200
20	13,000	39	20,800	5	1	39.00	53.97	13,000	0	2	3839	4039
21	9000	39	14,400	5	0	39.00	52.13	9000	0	3	5740	9780
22	7000	39	11,200	4	0	39.00	51.77	7000	0	3	5712	15,492
23	6000	39	9600	4	0	39.00	49.94	6000	0	3	5684	21,175
24	5000	39	8000	3	0	39.00	51.16	5000	0	3	5656	26,832
TOT	341,000							258,907	82,060		82,293	

### Chart 3 - System Two

#### 3 ICE MACHINES—5 CENTRIFUGALS

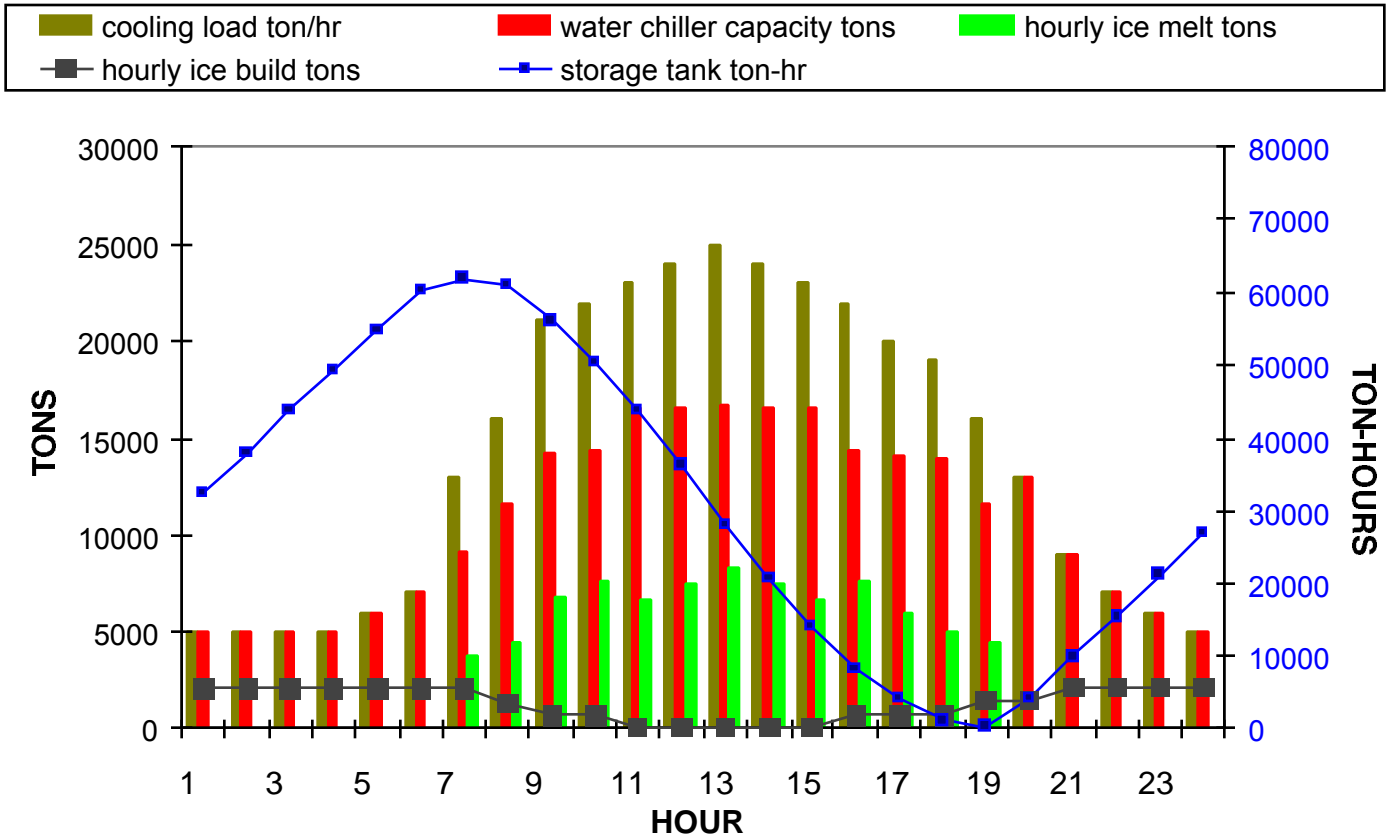

### SUMMARY

These two system simulations are summarized as follows:

System	Number of Centrifugals	Number of Screws	Machine Chilling Capacity	Peak Ice Melt Tons	Peak Ice Build Tons	Storage Ton-Hours
1	4	4	17,880	7777	7658	77,000
2	5	3	17,240	8275	5740	62,000

System Two probably has a cost advantage over System One in that the storage tank is smaller and the cost of five centrifugals and three screw machines would probably be less than the other combination.

## SYSTEM THREE

The flexibility of an ice slurry system can be illustrated in numerous ways. For example, let's assume that Phase One of the project has a relatively flat cooling load; i.e., the first customers on the District Cooling System operate 24 hours per day, such as a hospital. The analysis below illustrates that 50% of the daily ton-hours and a peak load of 9,000 tons versus 25,000 tons at the final phase, could be met with one ice machine and three centrifugal chillers. This combination could have an attractive return on investment. Note that the storage ton-hours is only 18,138, therefore about 40,000 ton-hours can be made during the week-end and held in reserve.

**Table 3 - System Three**

### ICE SLURRY—1 ICE MACHINE—3 CENTRIFUGALS—50% LOAD—9,000 TONS PEAK

End of Hour	Cooling Load ton/hr (100%)	System Supply Temp (°F)	Distribution System Chw Flow (gpm)	Centrifugal Water Chillers Operating	Screw Water Chillers Operating	Chiller Leaving Temp (°F)	Chiller Enter Temp (°F)	Water Chiller Capacity (tons)	Hourly Ice Melt (tons)	Number Compressors Making Ice	Hourly Ice Build (tons)	Storage Tank (ton/hr)
1	4000	39	6400	3	0	39.00	54.00	4000	0	1	1920	8648
2	4000	39	6400	3	0	39.00	48.73	4000	0	1	1906	10,554
3	4000	39	6400	3	0	39.00	48.73	4000	0	1	1903	12,457
4	4000	39	6400	3	0	39.00	48.73	4000	0	1	1900	14,356
5	5000	39	8000	3	0	39.00	51.16	5000	0	1	1897	16,253
6	6000	39	9600	3	0	39.69	53.59	5724	275	1	1893	17,871
7	7000	30	7000	3	0	35.57	48.64	5376	1624	1	1891	18,138
8	8000	30	8000	3	0	37.41	50.86	5528	2471	1	1890	17,557
9	9000	30	9000	3	0	38.92	52.67	5653	3345	1	1891	16,103
10	9000	30	9000	3	0	38.92	52.67	5653	3345	1	1894	14,652
11	9000	30	9000	3	0	38.92	52.67	5653	3345	1	1896	13,202
12	9000	30	9000	3	0	38.92	52.67	5653	3345	1	1898	11,756
13	9000	30	9000	3	0	38.92	52.67	5653	3345	1	1901	10,311
14	9000	30	9000	3	0	38.92	52.67	5653	3345	1	1903	8869
15	9000	30	9000	3	0	38.92	52.67	5653	3345	1	1905	7429
16	9000	30	9000	3	0	38.92	52.67	5653	3345	1	1908	5992
17	9000	30	9000	3	0	38.92	52.67	5653	3345	1	1910	4557
18	9000	30	9000	3	0	38.92	52.67	5653	3345	1	1913	3124
19	9000	30	9000	3	0	38.92	52.67	5653	3345	1	1915	1693
20	8000	39	12,800	3	0	43.23	54.00	5745	2254	1	1917	600
21	7000	39	11,200	3	0	41.69	54.00	5745	1254	1	1919	1265
22	6000	39	9600	3	0	39.70	53.61	5718	282	1	1918	2901
23	5000	39	8000	3	0	39.00	51.16	5000	0	1	1915	4816
24	4000	39	6400	3	0	39.00	48.73	4000	0	1	1912	6728
TOT	171,000							126,024	44,958		45,715	

**Chart 4 - System Three Cooling Load**

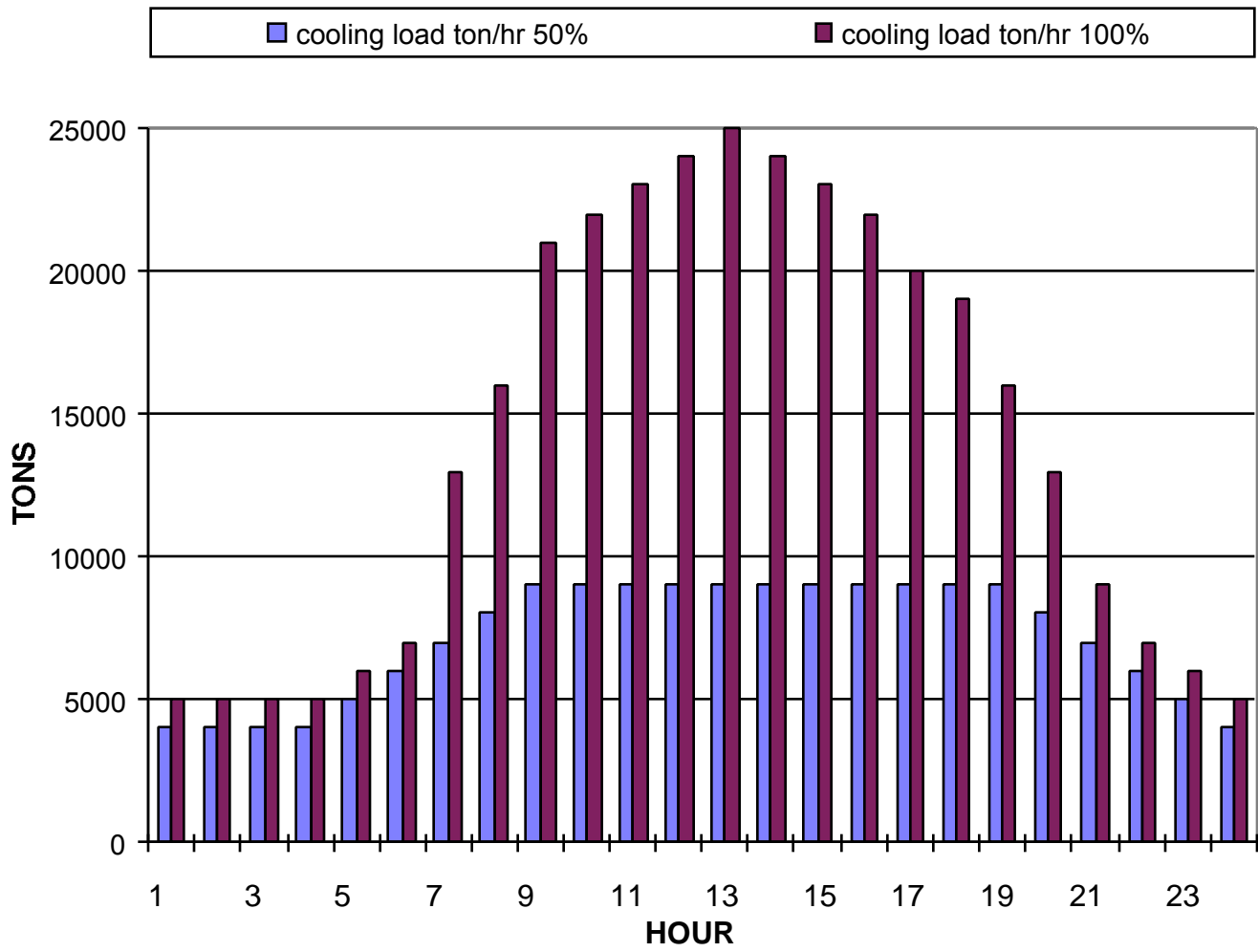

**Chart 5 - System Three**

**1 Ice Machine—3 Centrifugals—50% Load—9,000 Peak Tons**

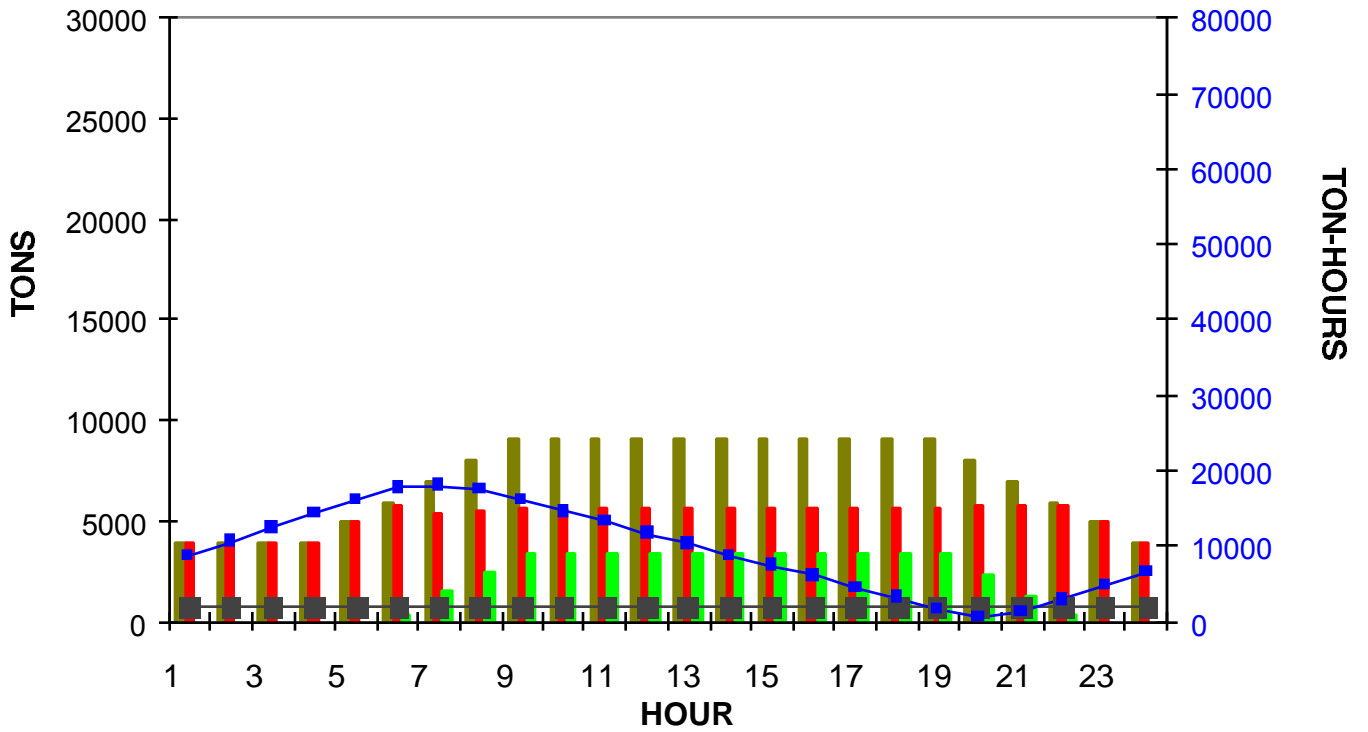
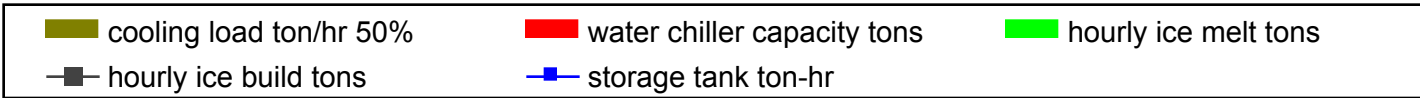

## SYSTEM FOUR

If Phase One of the project served office buildings, then the cooling load might be as assumed below, which is 50% of the daily ton-hours, and a peak load of 15,000 tons versus 25,000 tons at the final phase. This assumed load is the remainder of that assumed in System Three. In this system, two ice slurry machines are required and three centrifugals. However, one ice slurry machine could also meet this load with 4 or 5 centrifugal chillers. The point being that the equipment purchased could be optimized based on return on investment.

**Table 4 - System Four**

### ICE SLURRY—2 ICE MACHINE—3 CENTRIFUGAL—50% LOAD— 16,000 TONS PEAK

End of Hour	Cooling Load ton/hr (100%)	System Supply Temp (°F)	Distribution System Chw Flow (gpm)	Centrifugal Water Chillers Operating	Screw Water Chillers Operating	Chiller Leaving Temp (°F)	Chiller Enter Temp (°F)	Water Chiller Capacity (tons)	Hourly Ice Melt (tons)	Number Compressors Making Ice	Hourly Ice Build (tons)	Storage Tank (ton/hr)
1	1000	39	1600	1	0	39.00	46.29	1000	0	2	3766	26,503
2	1000	39	1600	1	0	39.00	46.29	1000	0	2	3753	30,257
3	1000	39	1600	1	0	39.00	46.29	1000	0	2	3741	33,998
4	1000	39	1600	1	0	39.00	46.29	1000	0	2	3729	37,726
5	1000	39	1600	1	0	39.00	46.29	1000	0	2	3717	41,443
6	1000	39	1600	1	0	39.00	46.29	1000	0	2	3704	45,147
7	6000	30	6000	2	0	38.93	52.68	3768	2232	2	3692	46,608
8	8000	30	8000	3	0	37.65	51.14	5449	2550	2	3687	47,745
9	12,000	30	12,000	3	0	42.51	54.00	5745	6252	2	3684	45,176
10	13,000	30	13,000	3	0	43.39	54.00	5745	7252	2	3692	41,616
11	14,000	30	14,000	3	0	44.15	54.00	5745	8252	2	3704	37,068
12	15,000	30	15,000	3	0	44.81	54.00	5745	9251	2	3719	31,536
13	16,000	30	16,000	3	0	45.38	54.00	5745	10,251	2	3737	25,022
14	15,000	30	15,000	3	0	44.81	54.00	5745	9251	2	3758	19,529
15	14,000	30	14,000	3	0	44.15	54.00	5745	8252	2	3776	15,053
16	13,000	30	13,000	3	0	43.39	54.00	5745	7252	2	3791	11,592
17	11,000	30	11,000	3	0	41.47	54.00	5745	5253	2	3802	10,141
18	10,000	30	10,000	3	0	40.21	54.00	5745	4253	2	3807	9694
19	7000	30	7000	2	0	40.87	54.00	3830	3169	2	3808	5000
20	5000	39	8000	2	0	42.51	54.00	3830	1170	2	3824	7654
21	2000	39	3200	1	0	39.77	53.69	1897	102	2	3815	11,367
22	1000	39	1600	1	0	39.00	46.69	1000	0	2	3803	15,169
23	1000	39	1600	1	0	39.00	46.29	1000	0	2	3790	18,960
24	1000	39	1600	1	0	39.00	46.29	1000	0	2	3778	22,738
TOT	170,000							85,224	84,742		90,076	

**Chart 6 - System Four Cooling Load**

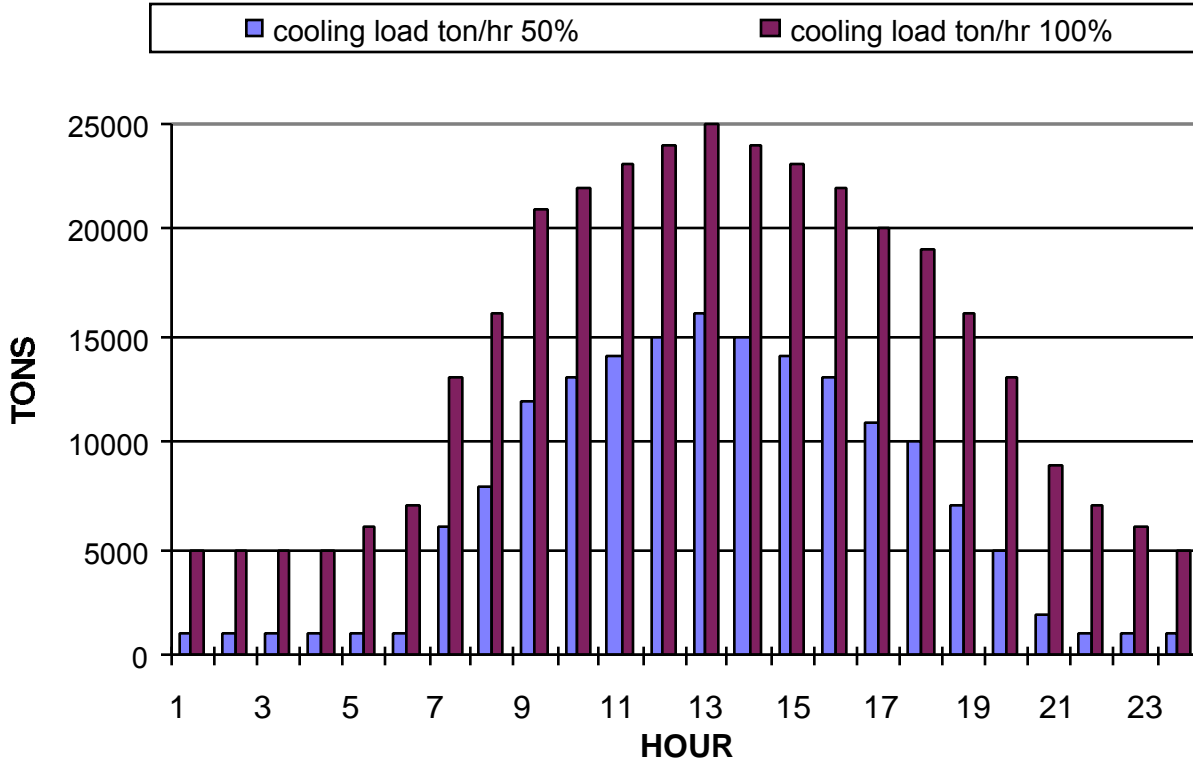

**Chart 7 - System Four**

**2 ICE MACHINES—3 CENTRIFUGALS—50% LOAD—16,000 TONS**

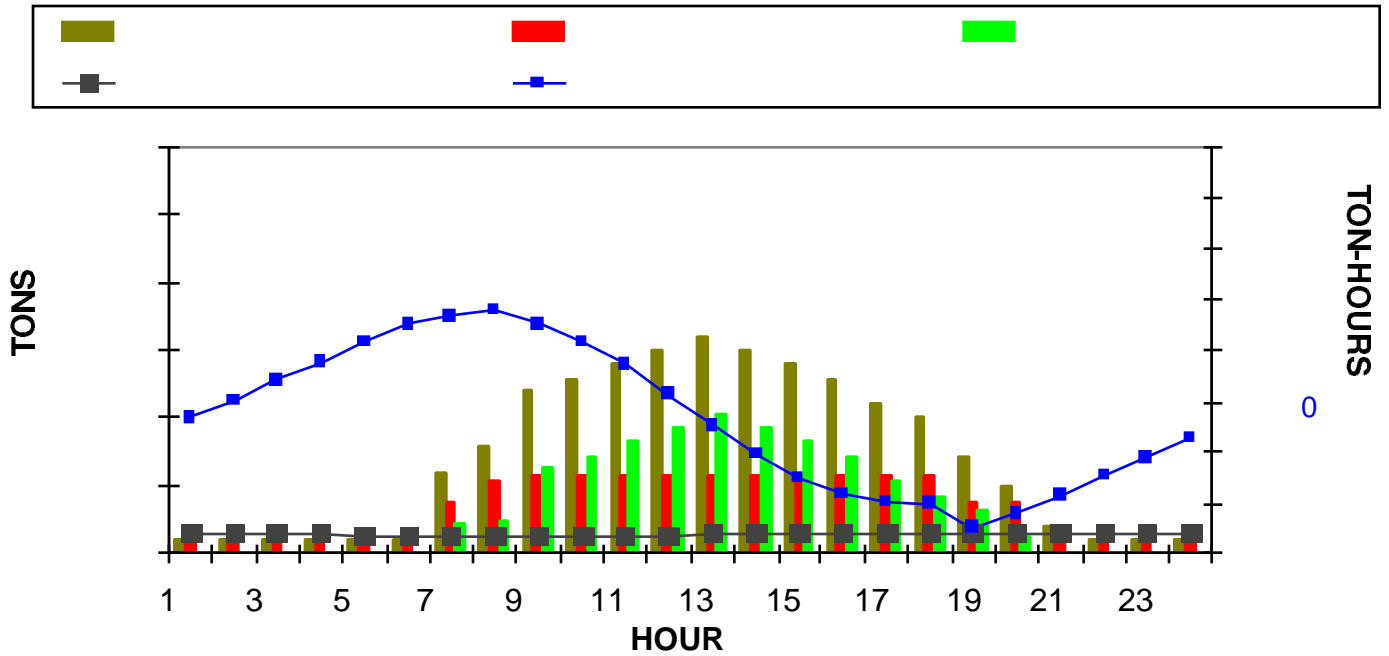

## SYSTEM FIVE

The analysis below illustrates that by adding five centrifugal chillers to System Four, for a total of eight, the two ice slurry machines can meet 100% of the load. Therefore, we see that the 100% load could be met by three combinations presented here:

- System One – 4 Screw Machines and 4 Centrifugals
- System Two – 3 Screw Machines and 5 Centrifugals
- System Five – 2 Screw Machines and 8 Centrifugals

Again, the point being that an ice slurry system offers the opportunity to optimize the cost effectiveness of the system based on how the system cooling load grows.

**Table 5 - System Five**

### ICE SLURRY—2 ICE MACHINES—8 CENTRIFUGALS—100% LOAD

End of Hour	Cooling Load ton/hr (100%)	System Supply Temp (°F)	Distribution System Chw Flow (gpm)	Centrifugal Water Chillers Operating	Screw Water Chillers Operating	Chiller Leaving Temp (°F)	Chiller Enter Temp (°F)	Water Chiller Capacity (tons)	Hourly Ice Melt (tons)	Number Compressors Making Ice	Hourly Ice Build (tons)	Storage Tank (ton/hr)
1	5000	39	8000	3	0	39.00	51.25	5000	0	2	3775	23,637
2	5000	39	8000	3	0	39.00	51.16	5000	0	2	3763	27,399
3	5000	39	8000	3	0	39.00	51.16	5000	0	2	3750	31,150
4	5000	39	8000	3	0	39.00	51.16	5000	0	2	3738	34,888
5	6000	39	9600	4	0	39.00	49.94	6000	0	2	3726	38,614
6	7000	39	11,200	4	0	39.00	51.77	7000	0	2	3714	42,327
7	13,000	30	13,000	5	0	37.08	50.45	9167	3831	2	3701	42,197
8	16,000	30	16000	6	0	37.41	50.86	11,057	4941	2	3702	40,958
9	21,000	30	21,000	8	0	37.20	50.61	14,696	6302	2	3706	38,362
10	22,000	30	22,000	8	0	37.82	51.34	14,832	7165	2	3714	34,911
11	23,000	30	23,000	8	0	38.39	52.03	14,958	8039	2	3726	30,598
12	24,000	30	24,000	8	0	38.92	52.67	15,076	8921	2	3740	25,418
13	25,000	30	25,000	8	0	39.42	53.27	15,186	9810	2	3757	19,364
14	24,000	30	24,000	8	0	38.92	52.67	15,076	8921	2	3777	14,220
15	23,000	30	23,000	8	0	38.39	52.03	14,958	8039	2	3793	9975
16	22,000	30	22,000	8	0	37.82	51.34	14,832	7165	2	3807	6617
17	20,000	30	20,000	8	0	36.54	49.81	14,549	5449	2	3818	4986
18	19,000	30	19,000	7	0	37.65	51.14	12,945	6053	2	3824	2757
19	16,000	30	16,000	6	0	37.41	50.86	11,057	4941	2	3831	800
20	13,000	39	20,800	7	0	39.00	52.55	13000	0	2	3837	4637
21	9000	39	14,400	5	0	39.00	52.13	9000	0	2	3825	8462
22	7000	39	11,200	4	0	39.00	51.77	7000	0	2	3812	12,275
23	6000	39	9600	4	0	39.00	49.94	6000	0	2	3800	16,074
24	5000	39	8000	3	0	39.00	51.16	5000	0	2	3787	19,862
TOT	341,000		384,800					251,387	89,577		90,424	

**Chart 8 - System Five**

**2 ICE MACHINES—8 CENTRIFUGALS**

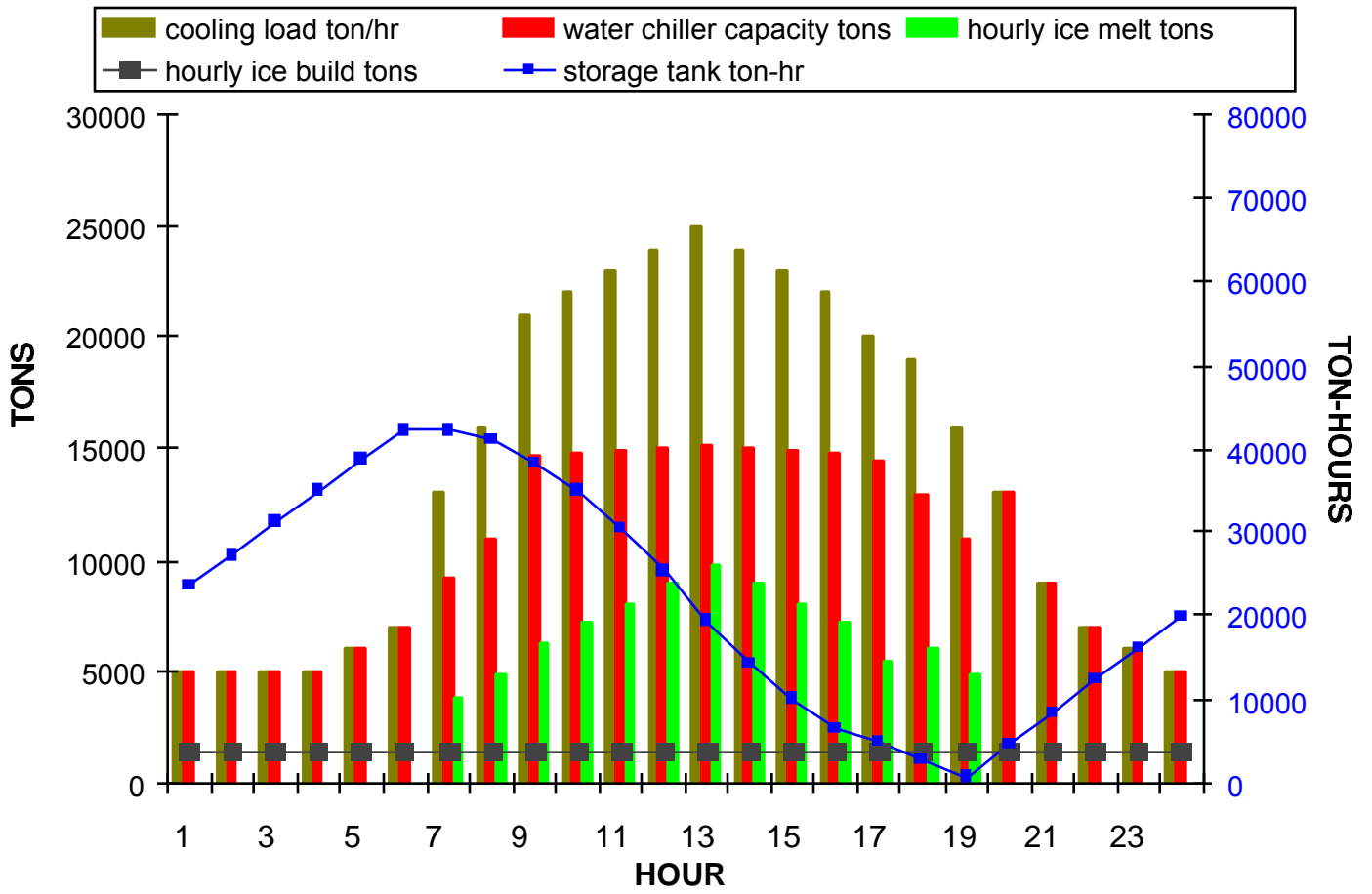

# SUMMARY

System	Number of Centrifugals	Number of Screws	Machine Chilling Capacity	Peak Ice Melt Tons	Peak Ice Build Tons	Storage Ton-Hours	% Load	Peak Tons
1	4	4	17,880	7777	7658	77,000	100	25,000
2	5	3	17,240	8275	5740	62,000	100	25,000
3	3	1	8300	3345	1919	19,000	50	9000
4	3	2	10,855	10,251	3824	48,000	50	15,000
5	8	2	20,430	9810	3837	43,000	100	25,000

System Five is probably the most cost effective ice slurry system for this assumed problem. Figure 2 illustrates the system.

**Figure 2 - System Five**

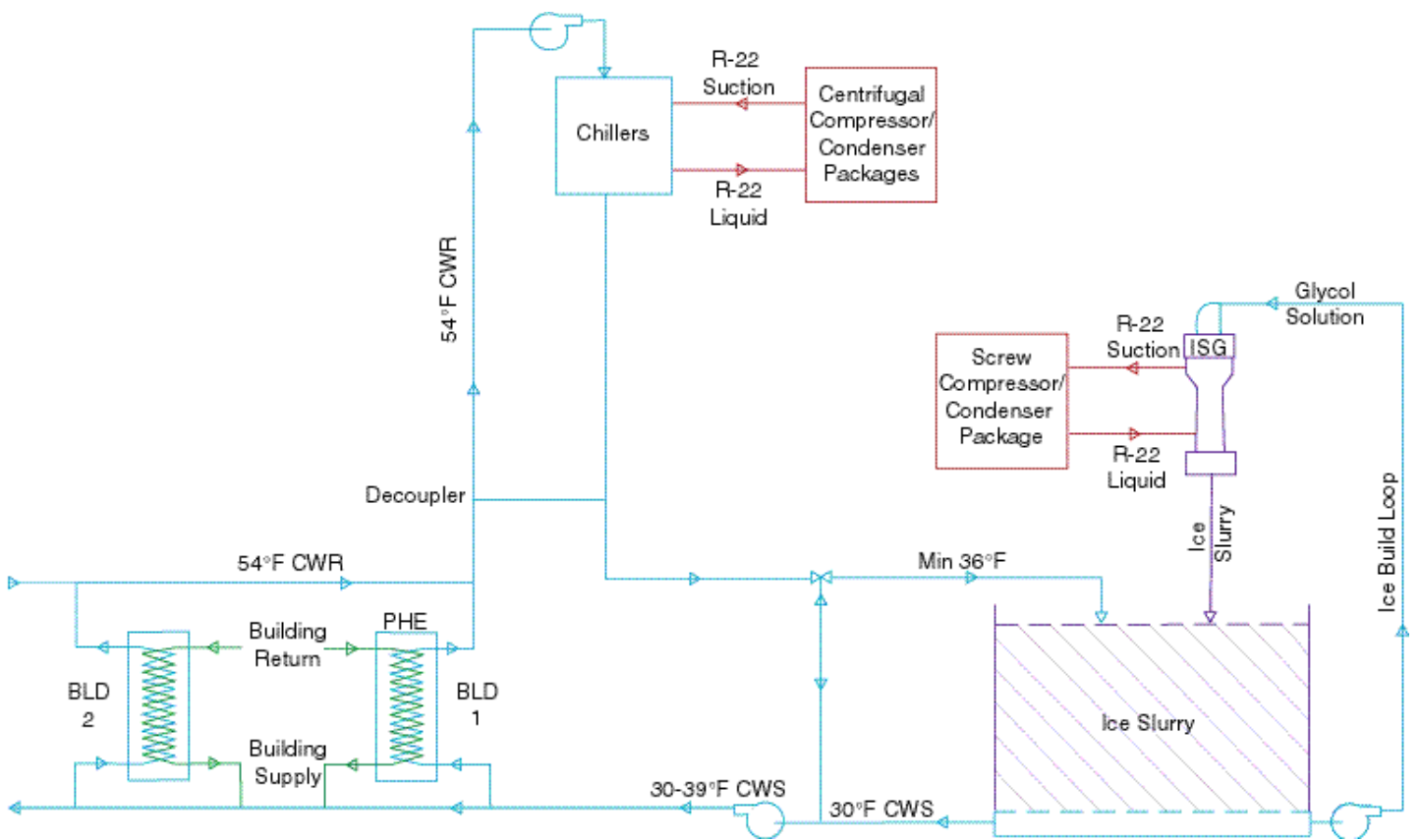

Note that Systems One, Two, and Five all meet the Final Phase of the project with very different equipment.

## SYSTEM SIX

As a final point regarding the flexibility of ice slurry, let's assume that the distribution system was installed assuming 34°F system supply temperature. Therefore, the distribution system would be designed for 30,000 gpm. If an ice slurry system was installed, then 30°F supply could meet 20% more peak load or 30,000 tons as shown in the analysis below, again illustrating the flexibility of an ice slurry system. The total ton-hours is also increased from 341,000 to 364,000.

**Table 6 - System 6**

### ICE SLURRY—3 ICE MACHINES—6 CENTRIFUGAL—107% LOAD— 30,000 TONS PEAK

End of Hour	Cooling Load ton/hr (100%)	System Supply Temp (°F)	Distribution System Chw Flow (gpm)	Centrifugal Water Chillers Operating	Screw Water Chillers Operating	Chiller Leaving Temp (°F)	Chiller Enter Temp (°F)	Water Chiller Capacity (tons)	Hourly Ice Melt (tons)	Number Compressors Making Ice	Hourly Ice Build (tons)	Storage Tank (ton/hr)
1	5000	39	8000	3	0	39.00	52.34	5000	0	3	5615	35,110
2	5000	39	8000	3	0	39.00	51.16	5000	0	3	5588	40,697
3	5000	39	8000	3	0	39.00	51.16	5000	0	3	5560	46,257
4	5000	39	8000	3	0	39.00	51.16	5000	0	3	5533	51,790
5	6000	39	9600	4	0	39.00	49.94	6000	0	3	5506	57,296
6	7000	39	11,200	4	0	39.00	51.77	7000	0	3	5479	62,775
7	13,000	30	13,000	6	0	35.50	47.68	10,021	2978	3	5452	65,249
8	16,000	30	16,000	6	0	37.41	50.86	11,057	4941	3	5440	65,747
9	21,000	30	21,000	6	1	38.34	51.97	13,703	7294	2	3625	62,077
10	24,000	30	24,000	6	2	37.91	51.45	16,092	7905	1	1818	55,991
11	26,000	30	26,000	6	3	37.07	50.45	18,338	7659	0	0	48,332
12	28,000	30	28,000	6	3	38.05	51.62	18,608	9388	0	0	38,944
13	30,000	30	30,000	6	3	38.92	52.67	18,849	11,147	0	0	27,797
14	28,000	30	28,000	6	3	38.05	51.62	18,608	9388	0	0	18,409
15	26,000	30	26,000	6	3	37.07	50.45	18,338	7659	0	0	10,750
16	24,000	30	24,000	6	2	37.91	51.45	16,092	7905	1	1902	4747
17	20,000	30	20,000	6	1	37.71	51.21	13,575	6422	2	3824	2149
18	19,000	30	19,000	6	1	37.03	50.39	13,437	5561	2	3833	421
19	16,000	30	16,000	6	0	37.41	50.86	11,057	4941	3	5758	1000
20	13,000	39	20,800	6	0	39.00	54.00	13,000	0	3	5755	6755
21	9000	39	14,400	5	0	39.00	52.13	9000	0	3	5727	12,482
22	7000	39	11,200	4	0	39.00	51.77	7000	0	3	5699	18,181
23	6000	39	9600	4	0	39.00	49.94	6000	0	3	5671	23,851
24	5000	39	8000	3	0	39.00	51.16	5000	0	3	5643	29,494
TOT	364,000							270,773	93,189		93,427	

**Chart 8 - System Six Cooling Load**

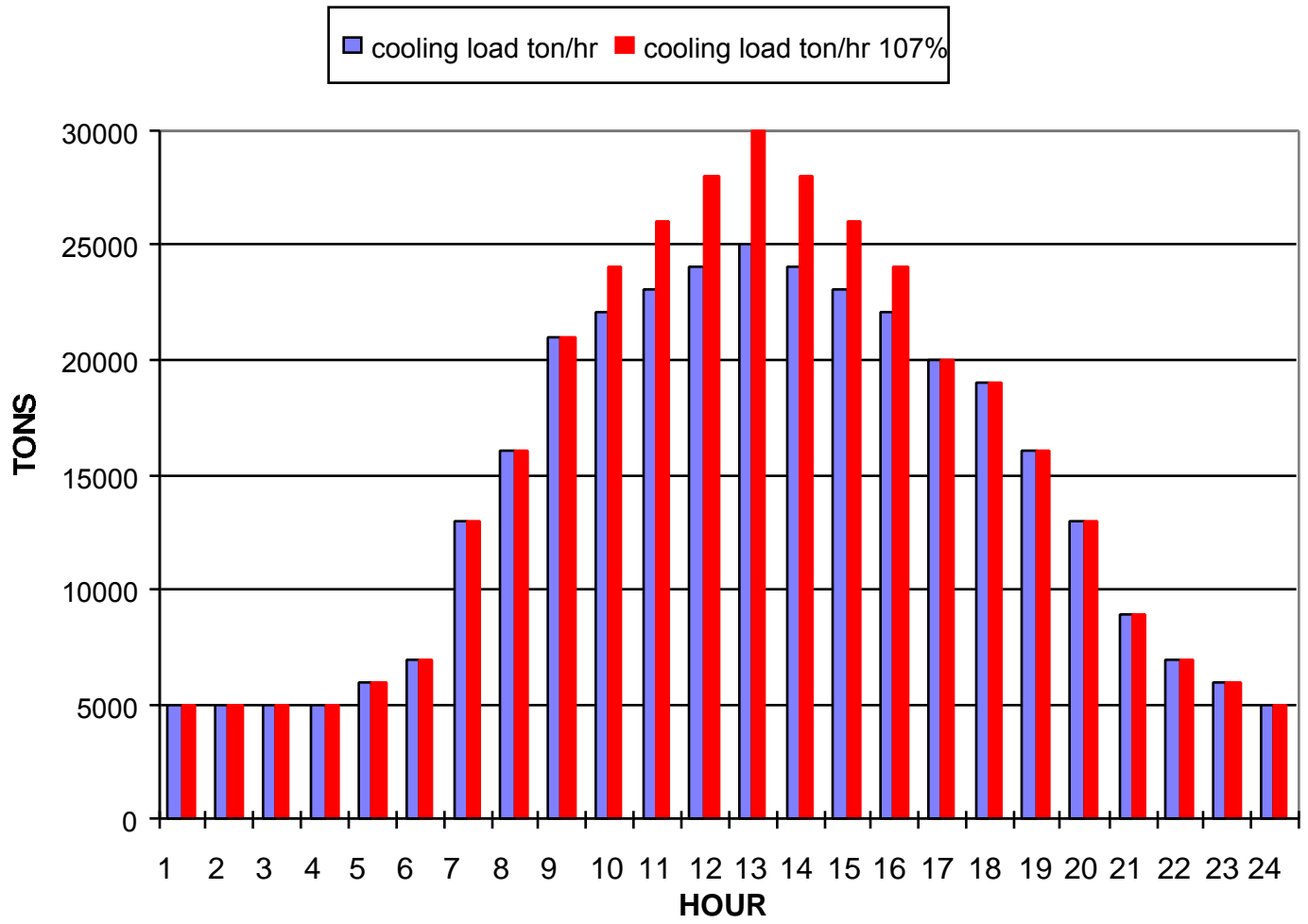

## Chart 10 - System Six

3 Ice Machines—6 Centrifugals—107% Load—30,000 Peak Tons

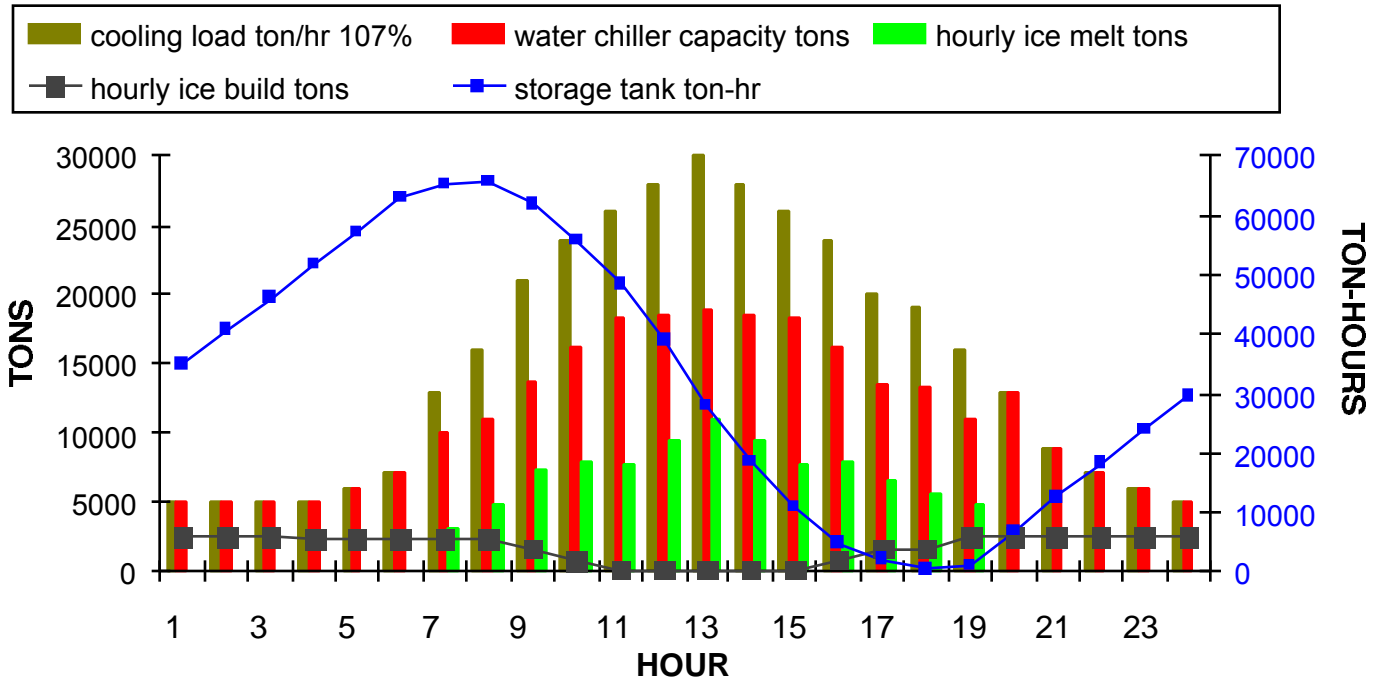

## CONCLUSION

The system analysis presented here has shown the system dynamics of an ice slurry system in a district cooling application. Characteristics which may be important are:

- (1) Ability to provide 30°F system supply temperature, and therefore decreased cost of the distribution system and/or pumping or the capability to meet greater cooling loads.
- (2) Flexibility of design so that, as the project grows, chilling or ice capacity can be added in the most cost-effective way and the final phase of the project will be determined by the final cooling loads rather than the cooling load estimates made at the beginning of the project. The potential result is better return on investment.

## REFERENCES

- Sam Gladis, M. J. Marciniak, J. B. O'Hanlon, P.E., Brad Yundt, P.E., 1996  
***Ice Crystal Slurry Ice TES System Using the Orbital Rod Evaporator.***  
EPRI Conference on Sustainable Thermal Energy Storage, August 7 - 9, 1996.
- William D. McCloskey  
***34° System Water Temperature Designs Save First Cost and Operating Cost***  
11th Annual IDEA College/University Conference  
Redondo Beach, CA, February 26, 1998
- Kirby P. Nelson, P.E.  
***Ice Slurry Generator***  
International District Energy Association, San Antonio, Texas, June 13-16, 1998