

MUELLER® BAKERY CHILLER

MODELS PMC 40/50 AND PMC 70/120

**INSTRUCTIONS FOR
INSTALLATION • OPERATION**

Part No. 9842311

Effective February 23, 1999

Revised May 7, 2009

MUELLER®
REFRIGERATION PRODUCTS



BAKERY CHILLER MODELS PMC 40/50 AND PMC 70/120 INSTRUCTIONS FOR INSTALLATION AND OPERATION

Table of Contents

Section 1.0 - Bakery Chiller Introduction

1.1	Introduction	1
1.2	Mueller Bakery Chiller Evaporator Assembly	1
1.3	Dimensions and Weight	1
1.4	Description of the Equipment	1
1.5	Refrigeration Components	2
1.6	Liquid Solution Flow Components	2
1.7	Electrical Components	2

Section 2.0 - Installation

2.1	Inspection	3
2.2	Safety	3
2.3	Location	3
2.4	Chilled Water Piping	3
2.5	Refrigeration Unit Installation	4

Section 3.0 - First Time Start-Up and Cleaning the System

3.1	First Time Start-Up and Cleaning Procedure	5
3.2	Filling the System	5

Section 4.0 - Programming and Troubleshooting

4.1	Power On Sequence of Operation	6
4.2	Error Messages	6
4.3	Locking and Unlocking Temperature Controller	7
4.4	Programming Temperature Setpoints	7
4.5	Changing Calibration Offset	7
4.6	Fahrenheit Celsius Conversion	8

Section 5.0 - Diagrams

5.1	Wiring Diagram, Part No. 9842313	9
5.2	Bakery Chiller PMC Model 70/120 Flow Diagram	10
5.3	Bakery Chiller PMC Model 40/50 Flow Diagram	10

Table of Contents - Continued

Section 6.0 - Parts Illustrations

6.1	Control Box11
6.2	Control Box Parts List11
6.3	Chiller Assembly Model PMC 40/5012
6.4	Chiller Assembly Parts List Model PMC 40/5013
6.5	Chiller Assembly Model PMC 70/12014
6.6	Chiller Assembly Parts List Model PMC 70/12015

Section 7.0 - Refrigeration Units

7.1	Specifications/Electrical Data for Model PMC 40/50 with 2 HP Unit16
7.2	Specifications/Electrical Data for Model PMC 70/120 with 3.5 HP Unit16
7.3	Refrigeration Cycle Diagram17
7.4	EPA Refrigerant Regulations17
7.5	Thermal Expansion Valve (TEV) Superheat Adjustment17
7.6	Thermal Expansion Valve Superheat Adjustment Diagram18

Section 8.0 - Warranty	19
---	----

Section 9.0 - Installation and Service Notes	20
---	----

SECTION 1.0 - INTRODUCTION

1.1 Introduction

The Mueller® bakery chiller is designed to provide chilled water at a preset temperature for batch applications. This manual provides the basic information necessary to install, start-up, and operate this Mueller bakery chiller. The information supplied in this manual must be followed to prevent damage to the equipment.

1.2 Mueller Bakery Chiller Evaporator Assembly

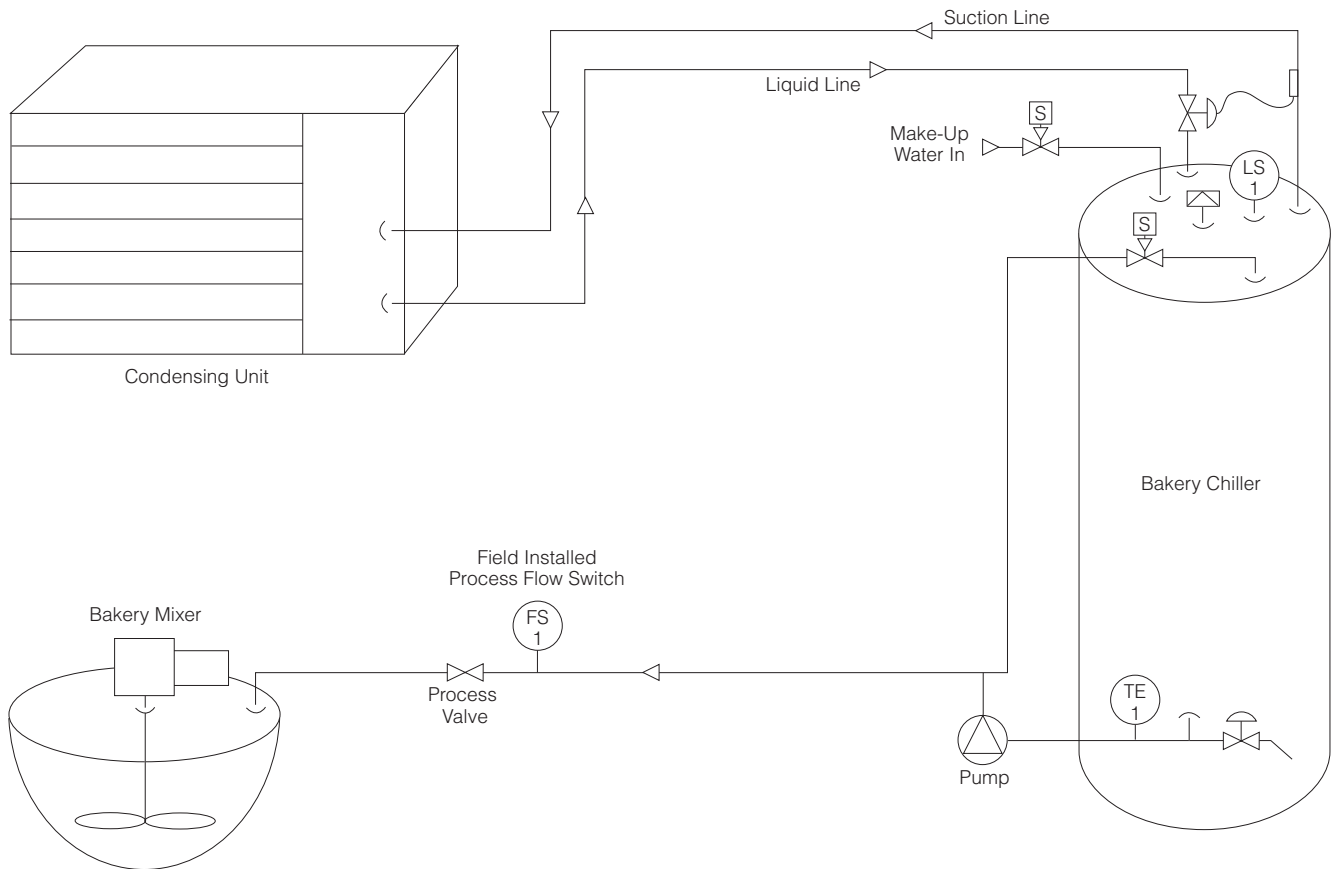

1.3 Dimensions and Weight

	PMC 40/50	PMC 70/120
Length	32"	42"
Width	24"	34"
Height	72"	84"
Approx. Shipping Weight	310 lbs.	705 lbs.

1.4 Description of the Equipment

The Mueller bakery chiller evaporator assembly is available in two sizes and two model variations to meet installation and application needs.

A. Sizes

1. PMC 40/50: Nominal 50-gallon storage capacity to be used with a 2 hp condensing unit.
2. PMC 70/120: Nominal 120-gallon storage capacity to be used with a 3.5 hp condensing unit.

B. Model Variations

1. RC: Evaporator assembly and remote condensing unit.
2. RS: Evaporator assembly and solenoid valve for a rack system.

Example: PMC 40/50 RC

1.5 Refrigeration Components

The refrigeration components of the evaporator assembly include a thermal expansion valve for refrigerant control, a stainless steel evaporator that is outside of a baked, glass-lined water tank, and inner-connect refrigerant piping. Single-point refrigeration piping connections are provided for ease of installation that is described in Section 2.5.

1.6 Liquid Solution Flow Components

The liquid solution flow components include a baked, glass-lined, and insulated water storage tank, water solenoid valve to control make-up water and recirculation, circulation pump, and inner-connect piping. Single point $\frac{3}{4}$ " MPT connections are provided for water inlet and chilled water outlet. This system is designed to maintain the water level in the storage tank after each batch of chilled water is drawn. Make-up water will not enter the storage tank during the batch draw which eliminates temperature blending of warmer make-up water and chilled water.

1.7 Electrical Components

All wiring must be performed in compliance with the National Electric Code and local codes and regulations.

The control box contains fuses for system protection. Fuse failure requires troubleshooting to determine the cause of failure and replacement with the same fuses as described in Section 5.0.

The electronic temperature control can be set for temperature control of chilled water and temperature display in Fahrenheit or Celsius. Programming is described in Section 4.0.

SECTION 2.0 - INSTALLATION

2.1 Inspection

Because it is possible for equipment to be damaged during shipment, we recommend that you make a thorough inspection of all equipment before it is unloaded from the freight truck. Carefully inspect equipment for hidden damage. It may be difficult to collect for damage if it is not found prior to unloading. It is very important to note any damage on the bill of lading and have the driver sign it.

2.2 Safety

Installation and service should be performed by an authorized service technician who has the proper training to install and service refrigeration equipment. Effective November 1994, the service technician must be certified in refrigerant usage by an EPA-approved testing organization prior to installing or servicing any refrigeration equipment.

All electrical connections must be performed by a qualified electrician in accordance with local and NEC regulations.

2.3 Location

When choosing a location for the Mueller bakery chiller, consider these items:

- **Environment:** An indoor location will be necessary where the chiller section is protected from freezing temperature.
- **Serviceability:** The chiller should be located with the circulating pump and the control panel accessible for service. Keep in mind the chiller will require field connections to the main electrical supply and water supply line. The chiller should be located close to a drain for service and cleaning.
- **Refrigeration Unit:** The refrigeration unit (for PC and RC models) must be located where they are protected from the environment and have adequate air-flow for the condenser. Be especially cautious of conditions that would allow dust or oil to enter the condenser.
- **Efficiency:** Locate the chiller as close as possible to point of use for chilled water.

2.4 Chilled Water Piping

The bakery chiller supply water should be connected to the $\frac{3}{4}$ " inlet water solenoid valve located at the top of the water tank (refer to Figure 3, "Flow Diagram"). The supply water line should be taken from a source that provides adequate water flow and a minimum of $\frac{3}{4}$ " in size. It is recommended that a full flow shut-off valve and union be installed just prior to the solenoid valve for service.

The chilled water supply should be connected to the $\frac{3}{4}$ " chilled water outlet located near the circulation pump. Keep this line as short as possible to allow for chilled water of desired temperature to be provided to point(s) of use. This line should be insulated to reduce external heat gain to the chilled water.

Check all piping for leaks and repair if required. Clean and rinse lines and water storage tank prior to usage.

2.5 Refrigeration Unit Installation

All refrigerant piping should be in accordance to acceptable refrigeration practices. Distance between refrigeration unit and bakery chiller assembly should be as close as possible. Long distance piping and risers may require attention to reduce restriction of refrigerant flow and to provide adequate oil return.

The liquid line should be $\frac{3}{8}$ " OD copper pipe and the suction line $\frac{7}{8}$ " OD copper pipe. A liquid line drier of adequate size should be installed on all PMC 40/50 RS and RC models. A liquid line drier is provided on 3.5 hp. units for PMC 70/120 RS and RC models. A liquid line sight glass should be installed just prior to the thermal expansion valve (TEV) on the bakery chiller evaporator assembly. Attach the thermal expansion valve sensing bulb to the suction line and insulate after refrigerant lines are installed as shown in Section 7.3 and Figure 7.

Evacuation to 500 microns prior to charging with refrigerant is required. The system must hold 1,000 microns in a standing vacuum test, ensuring that it is leak free.

Refrigerant charging should be through the suction service valve in vapor form only. Charge with an adequate amount of refrigerant prior to starting the compressor and make sure that water storage tank is filled with water. Refer to Section 3.0 for start-up procedures.

The initial refrigerant charge for PMC 40/50 model with a 2 hp unit is 6 lbs R-22 or 5 lbs. R-507 refrigerant. The initial refrigerant charge for PMC 70/120 models with a 3.5 hp unit is 13 lbs R-22 or 12 lbs. R-507 refrigerant.

SECTION 3.0 - FIRST TIME START-UP AND CLEANING THE SYSTEM

3.1 First Time Start-Up

1. Make sure that the water piping is complete as described in Sections 2.4 and 5.0, Figure 3, and refrigeration piping is complete as described in Sections 2.5 and 7.0. Make sure that the wiring is complete as described in Section 5.0.
2. The first step to start-up will be to open the supply water shut-off valve(s). Open the drain valve located at the outlet of the water storage tank. A toggle switch that disables the circulation pump is located inside the control box in the upper right hand corner of the back panel. The up position will allow the pump to run and the down position will disable the pump. **Any time the tank is empty, or on initial start-up, the operator must disable the circulation pump. This will allow the fill solenoid to fill the tank and prevent the pump from running dry.** Turn the toggle switch to the down position. Turn the power on to the control panel. Make sure the power is off to the refrigeration unit during this part of start-up. Push the green push button switch on the front of the control panel to energize the system. This will allow water to flow to the storage tank. Allow water to flow until clean and clear water is flowing out of the drain. Close the drain valve and allow the storage tank to fill.
3. Turn the toggle switch to the up position and allow the circulation pump to operate for 2 minutes and turn the push button switch off. Open the drain valve again and drain the water from the storage tank. If the water is not clean repeat the cleaning procedure.

3.2 Filling the System

1. Close the drain valve, turn the toggle switch to the down position, and turn the push button switch on to fill the system with water again. Open the chilled water valve and allow water to flow until clean. Close the chilled water valve and allow the storage tank to refill with make-up water. Turn the toggle switch to the up position to operate the circulation pump.
2. Complete the initial refrigeration unit charging procedure. Final refrigerant charging is to be completed in conjunction with the thermal expansion valve (TEV) superheat adjustment as described in Section 7.0.

SECTION 4.0 - PROGRAMMING AND TROUBLESHOOTING

4.1 Power On Sequence of Operation

A. When the push button is in the OFF (out) position:

1. Power is supplied to the temperature controller and a temperature is displayed. Setpoints may be changed any time power is supplied to the temperature controller. **The temperature displayed may not be a true reading of tank temperature if the circulation pump is not running.**
2. All other functions of the bakery chiller are disabled.

B. When the push button is in the ON (recessed) position:

1. Power is supplied to the temperature controller and a temperature is displayed. Setpoints may be changed any time power is supplied to the temperature controller. **The temperature displayed may not be a true reading of tank temperature if the circulation pump is not running.**
2. The system light at the center of the on/off button is on.
3. The fill solenoid will allow the tank to fill until the level switch stops the fill near the top of the storage tank.
4. The circulation pump is on. **Any time the tank is empty, or on initial start up, the operator must disable the circulation pump. This will allow the fill solenoid to fill the tank and prevent the pump from running dry.** Refer to Section 3.1, "First Time Start-up" for detailed information.
5. Water will flow through the chiller recirculation loop piping and solenoid to the top of the tank.
6. The condensing unit will operate if the water temperature is above the setpoint.
7. When a batch is drawn, the flow through the process piping increases and will open the process flow switch contacts, disabling the fill solenoid and condensing unit, and closing the recirculation solenoid.
8. When the batch draw is complete, the process flow switch contacts close and the fill solenoid will refill the storage tank. When the storage tank is full, the temperature controller again has control of the condensing unit.

4.2 Error Messages

A display reading of "uuuu" is a designation of a disconnected or broken temperature sensor wire. Should this occur, service is required to correct the problem.

4.3 Locking and Unlocking the Temperature Controller

1. Press and hold the “SEL” key for 5 seconds until “AL1” is displayed. Press the “↓” down key once to display “LoC.”
2. Press the “SEL” key once again to display the locking code (“0” for unlocked and “4” for locked).
3. Press the “↑” up key or the “↓” down key until either “0” for unlocked or “4” for locked is displayed. (**NOTE:** You can enter any number between “0” and “5” but only “0” and “4” are active.)
4. Press the “SEL” key to save the change made. Controller will once again display “LoC.”
5. Press and hold the “SEL” key for 5 seconds until the setpoint value is displayed, indicated by a small “SV” illuminating in the upper left-hand corner of the controller.
6. Press the “SEL” key to display the current tank temperature.

NOTE: If the “SEL” key is not pressed within approximately 25 seconds the controller will time out and return to the current temperature, storing the new setpoint or any changes made.

4.4 Changing the Setpoint on the Temperature Controller

1. Unlock the controller as in Section 4.3.
2. Press the “SEL” once to display the setpoint. This is indicated by a small “SV” illuminating in the upper left-hand corner of the controller.
3. Press the “↑” up key or the “↓” down key until the desired setpoint is displayed.
4. Press the “SEL” key to save the change made and to display the current tank temperature.

NOTE: If the “SEL” key is not pressed within approximately 25 seconds the controller will time out and return to the current temperature, storing the new setpoint or any changes made.

4.5 Changing the Calibration Offset on the Temperature Controller

1. Unlock the controller as in Section 4.3.
2. Press and hold the “SEL” key for 7 seconds until “P-F” is displayed.
3. Press the “↓” down key once to display “PUOF.”
4. Press the “SEL” key once to display the calibration offset.
5. Press the “↑” up key or the “↓” down key to adjust the calibration offset to the amount of offset required to match the actual water temperature. (The calibration offset may be used to set the actual temperature display should it not be the same as the water temperature in the storage tank.)
6. Press the “SEL” key to save the change made. Controller will once again display “PUOF.”
7. Press and hold the “SEL” key for 5 seconds until the setpoint value is displayed, indicated by a small “SV” illuminating in the upper left hand corner of the controller.

4.5 Changing the Calibration Offset on the Temperature Controller (Continued)

8.. Press the “SEL” key to display the current tank temperature.

NOTE: If the “SEL” key is not pressed within approximately 25 seconds the controller will time out and return to the current temperature, storing the new setpoint or any changes made.

4.6 To Change the Units of Measure on the Temperature Controller:

NOTE: Once the display has been changed to the desired units of measure (°F or °C), the temperature setpoint must also be changed to match the units (i.e., 36°F or 2.2°C). Call Paul Mueller Company for assistance.

1. Unlock the controller as in Section 4.3.
2. Press and hold the “SEL” key for 7 seconds until “P-F” is displayed.
3. Press the “SEL” once to display the current temperature unit of measure (“F” for Fahrenheit and “C” for Celsius).
4. Press the “↑” up key or the “↓” down key until either “F” for Fahrenheit or “C” for Celsius is displayed.
5. Press the “SEL” key to save the change made. Controller will once again display “P-F.”
6. Press and hold the “SEL” key for 5 seconds until the setpoint value is displayed, indicated by a small “SV” illuminating in the upper left hand corner of the controller.
7. Press the “SEL” key to display the current tank temperature.

NOTE: If the “SEL” key is not pressed within approximately 25 seconds the controller will time out and return to the current temperature, storing the new setpoint or any changes made.

SECTION 5.0 - DIAGRAMS

5.1 Wiring Diagram, Part No. 9842313

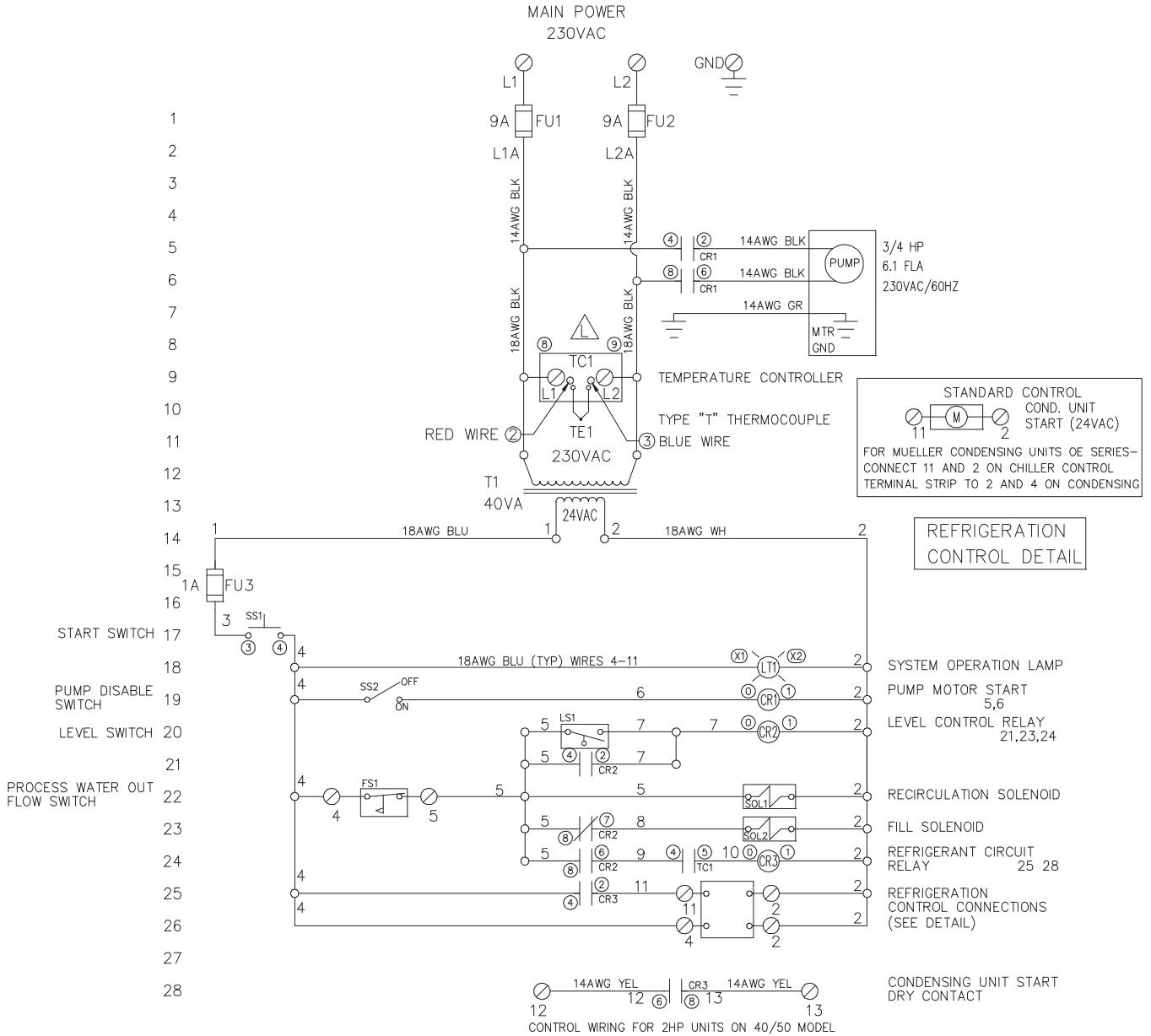

9842313
9001759-D REV. M

A Type T thermocouple is provided for the temperature sensor. It is important that the thermocouple wires are connected to the temperature control properly. The constantan (silver) wire is to be connected to terminal 10 on the temperature control. The copper wire is to be connected to terminal 11 on the temperature control.

5.2 Bakery Chiller PMC Model 70/120 Flow Diagram

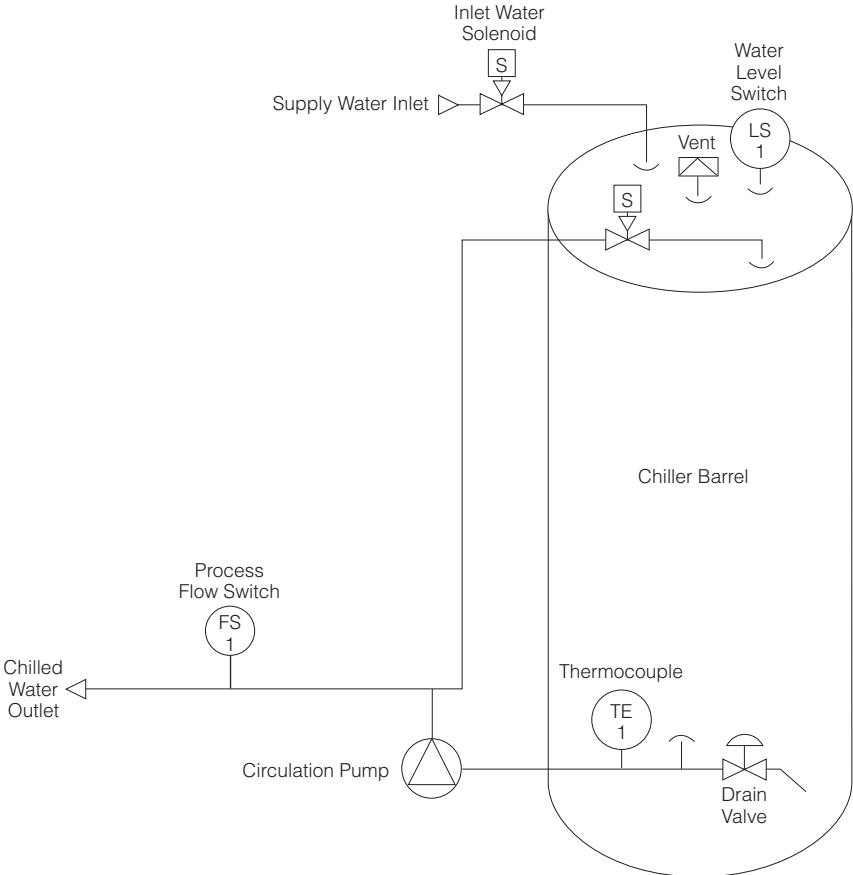

5.3 Bakery Chiller PMC Model 40/50 Flow Diagram

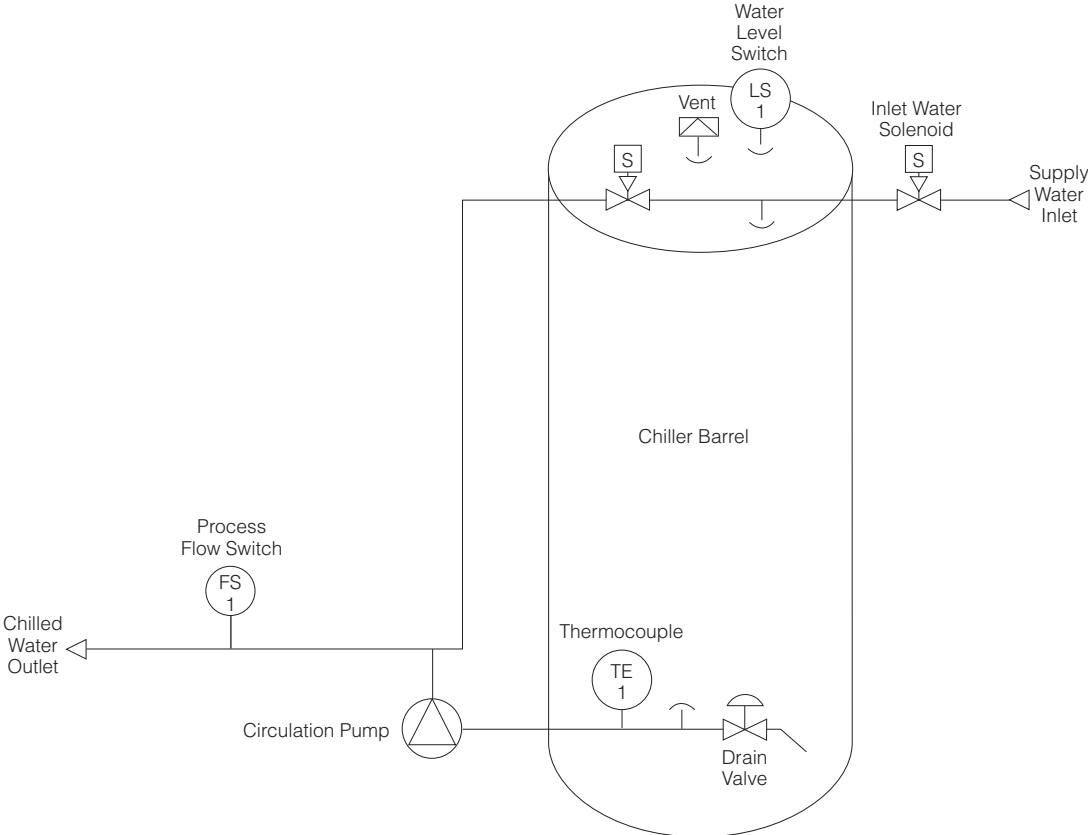

SECTION 6.0 - PARTS ILLUSTRATIONS

6.1 Control Box

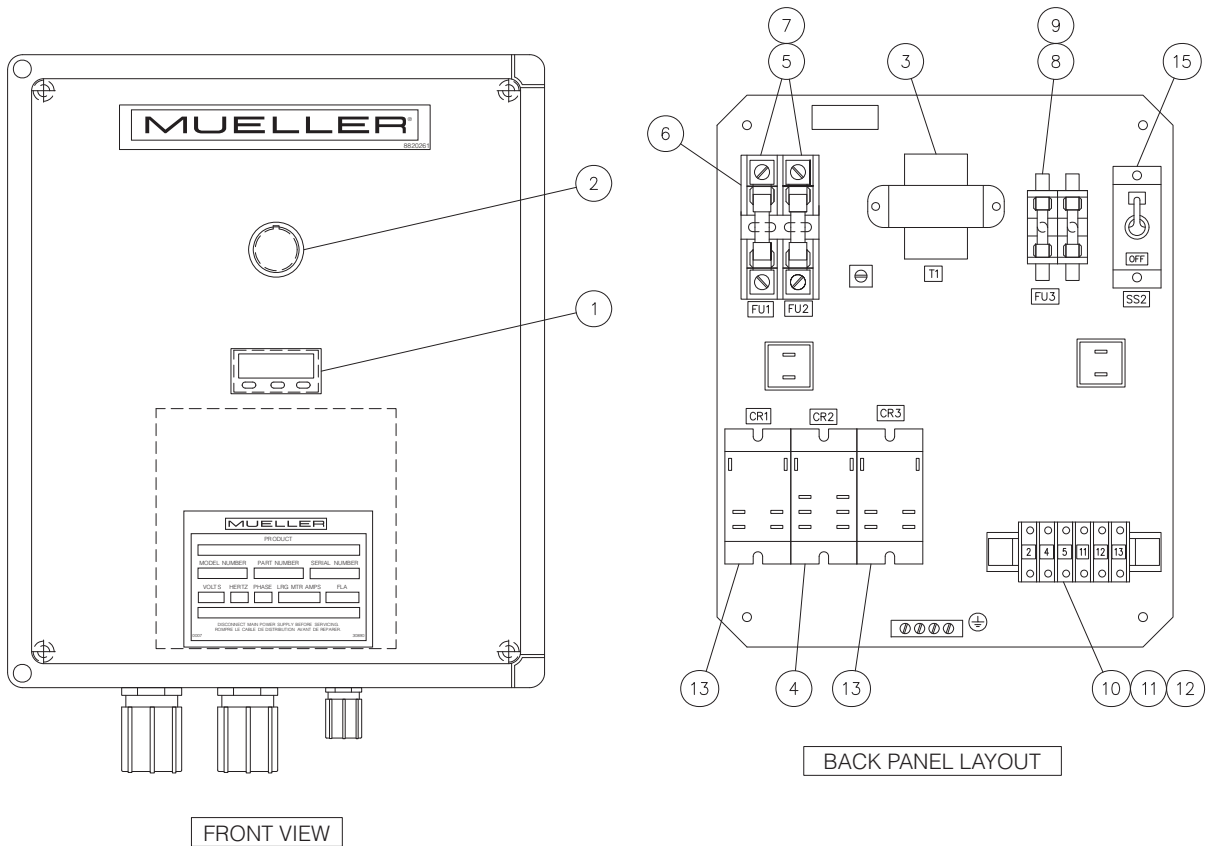

6.2 Control Box Parts List

ITEM NO.	NO. REQ'D.	PART NO.	DESCRIPTION
	1	9842292	CONTROL BOX ASSEMBLY - BAKERY
1	1	9844261	CONTROLLER, TEMPERATURE
2	1	9842305	SWITCH, PUSH BUTTON, LIGHTED
3	1	8820718	TRANSFORMER, 208-240V, PRM, 24V SEC
4	1	9842306	SWITCH, RELAY, DPDT, 24VAC
5	2	9820091	FUSE BLOCK, 30 AMP, CLASS CC
6	1	505793	BARRIER, ELEC END FUSE
7	2	9823754	FUSE, CARTRIDGE, 7 AMP
8	2	8820703	FUSE, BLOCK, 30 AMP
9	1	8806523	FUSE, CARTRIDGE, 2 AMP
10	6	8805635	TERMINAL BLOCK
11	1	8805636	BARRIER, ELEC END
12	2	8805226	CLIP, RETAINER
13	2	8820240	RELAY, SWITCH, DPST, 24VAC
14	1	8820165	THERMOCOUPLE, SENSOR, TYPE "T"
15	1	30853	SWITCH, TOGGLE, DPST

6.3 Chiller Assembly Model PMC 40/50

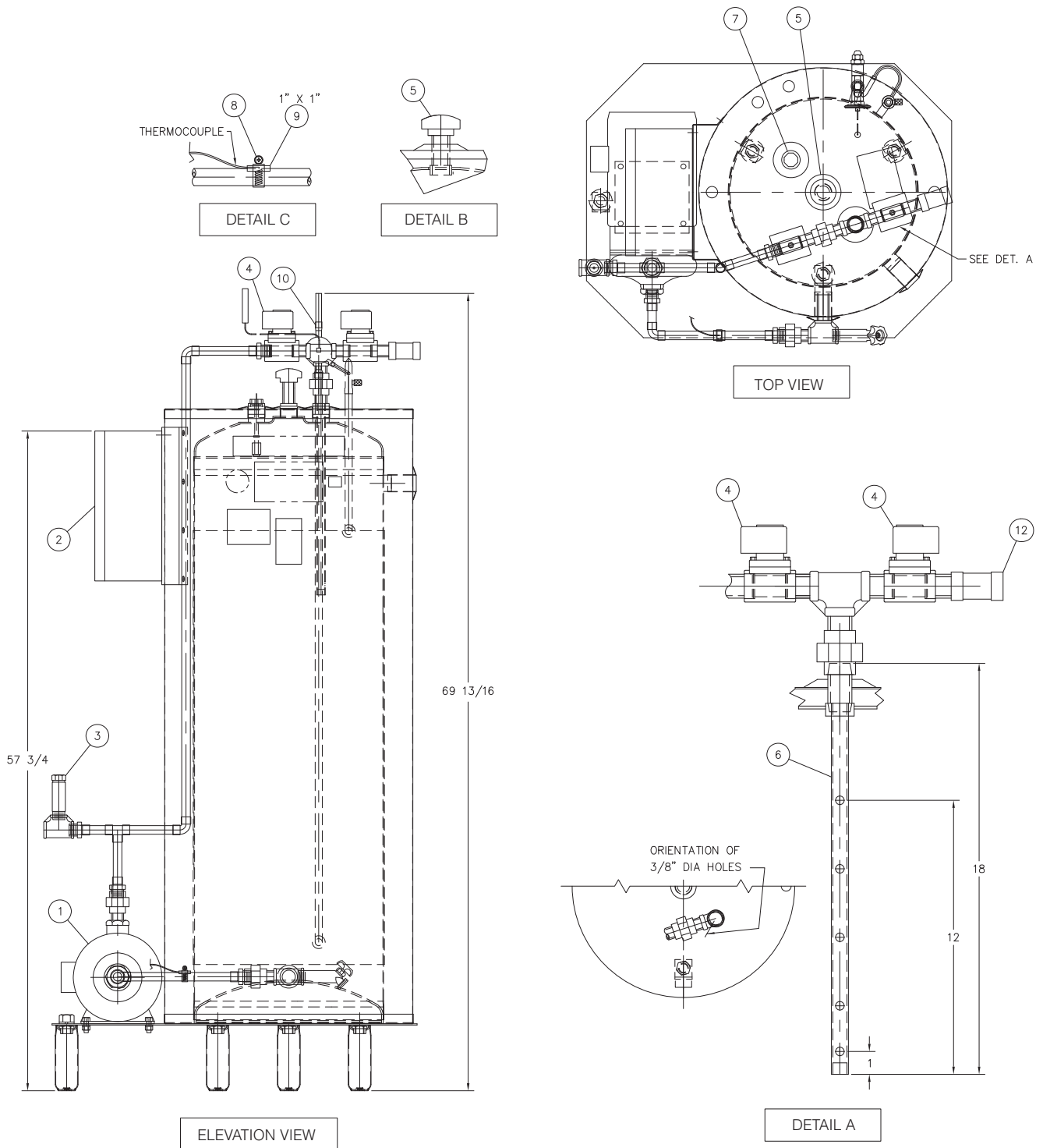

6.4 Chiller Assembly Parts List Model PMC 40/50

ITEM NO.	NO. REQ'D.	PART NO.	DESCRIPTION
	1	9842289	CHILLER, BAKERY MODEL PMC 40/50
1	1	9842259	WATER PUMP, CIRCULATING, .75HP
2	1	9842292	CONTROL BOX ASSEMBLY
3	1	9842309	SWITCH, FLOW, MAGNETIC
4	2	9842295	VALVE, SOLENOID, .75" NPT
5	1	9842300	VENT, TANK, .75" FPT
6	1	8802042	TUBE, INLET WATER
7	1	9843059	SWITCH, LEVEL
8	1	30041	CLAMP, HOSE
9	.007SF	3202023	RUBBER, .125" THK
10A	1	9842303	VALVE, EXPANSION, R-22
10B	1	9844289	VALVE, EXPANSION, R-507
11	3	93755	LEG, ASSEMBLY
12	1	9843187	REGULATOR FLOW .75", 10 GPM

6.5 Chiller Assembly Model PMC 70/120

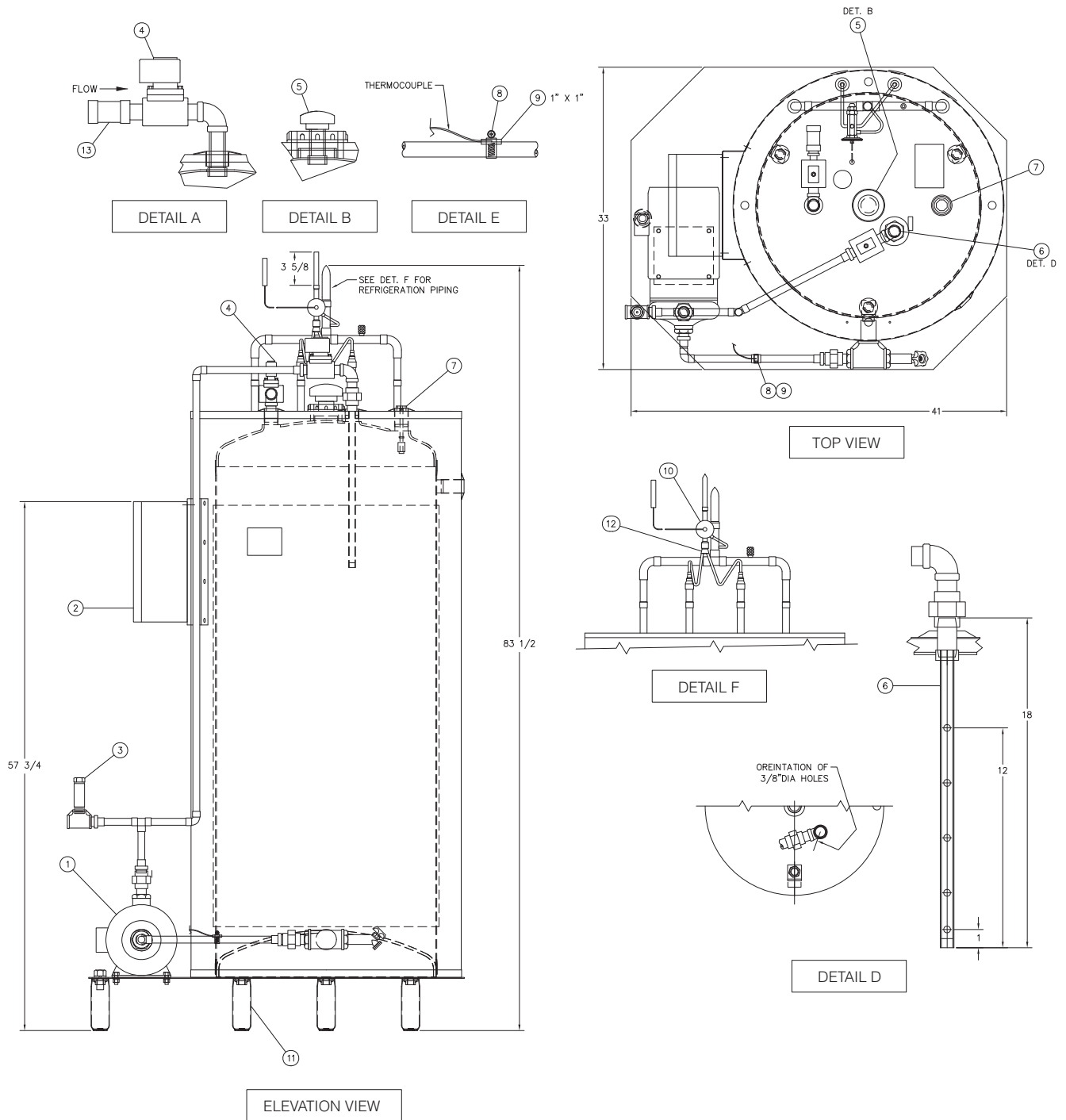

6.6 Chiller Assembly Parts List Model PMC 70/120

ITEM NO.	NO. REQ'D.	PART NO.	DESCRIPTION
	1	9842291	CHILLER, BAKERY MODEL PMC 70/120
1	1	9842259	PUMP, WATER, CIRCULATING, .75HP
2	1	9842292	CONTROL BOX ASSEMBLY
3	1	9842309	SWITCH, FLOW, MAGNETIC
4	2	9842295	VALVE, SOLENOID, .75" NPT
5	1	9842315	VENT, TANK, 1.25" FPT
6	1	8802042	TUBE, INLET WATER
7	1	9843059	SWITCH, LEVEL
8	1	30041	CLAMP, HOSE
9	.007SF	3202023	RUBBER, .125" THK
10A	1	8802355	VALVE, EXPANSION, R-22
10B	1	9844291	VALVE, EXPANSION, R-507
11	4	93755	LEG, ASSEMBLY
12	1	9842317	DISTRIBUTOR
13	1	9843187	REGULATOR FLOW .75", 10 GPM

SECTION 7.0 - REFRIGERATION UNITS

7.1 Specifications/Electrical Data for PMC 40/50 With 2 HP Unit

SPECIFICATIONS								
Part Number	Unit Model Number	Overall Dimensions (inches)			Liquid Line Valve	Suction Line Valve	Approximate Shipping Weight (lbs.)	Compressor Model No.
		Length	Width	Height				
9842322	F3AM-A201	24.1	18.3	16.9	3/8 FL	7/8 SWT	140	CRD1-0201
9844295	FJAM-A150	24.1	18.3	16.9	3/8 FL	7/8 SWT	140	CS10K6E

ELECTRICAL DATA			
Unit Model Number	208-230/1/60		
	Elec. Code	M/C Amps	Max Fuse
F3AM-A201	-CFV	19.7	30
FJAM-A150	-CFV	19.7	30

7.2 Specification/Electrical Data for PMC 70/120 With 3.5 HP Unit

SPECIFICATIONS								
Part Number	Unit Model Number	Overall Dimensions (inches)			Liquid Line Valve	Suction Line Valve	Approximate Shipping Weight (lbs.)	Compressor Model No.
		Length	Width	Height				
8822363	OESE-A351	40.1	30.4	31.5	3/8 SWT	7/8 SWT	358	ZB26KA-PFV
8822362	OESE-A353	40.1	30.4	31.5	3/8 SWT	7/8 SWT	358	ZB26KA-TFS

ELECTRICAL DATA				
Unit Model Number	208-230/1/60		208-230/3/60	
	M/C Amps	Max Fuse	M/C Amps	Max Fuse
OESE-A351	23.0	30		
OESE-A353			16.5	20

NOTE: The 2.0 hp remote condensing unit is suitable for outdoor operation with the addition of low-ambient controls and weather protection. Call the factory for more information.

7.3 Refrigeration Cycle Diagram

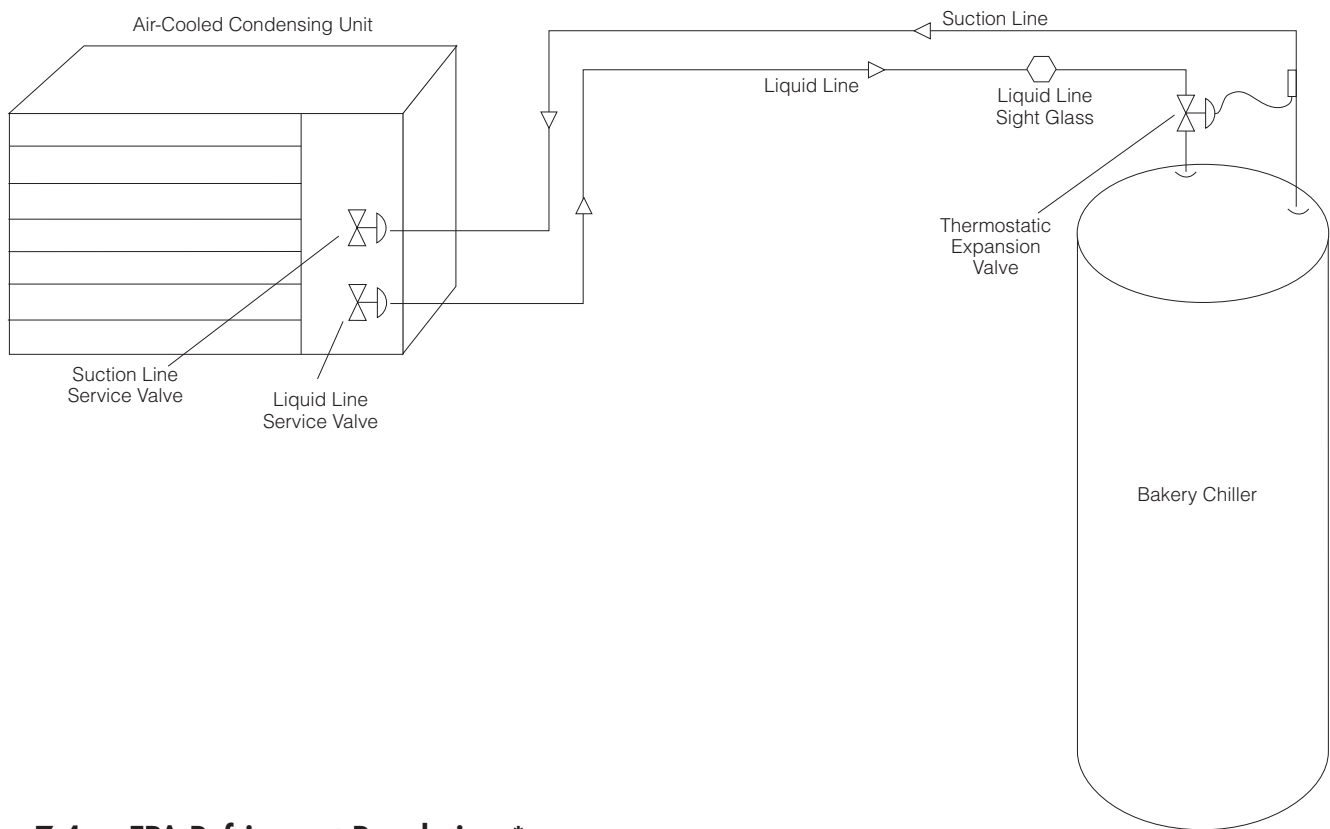

7.4 EPA Refrigerant Regulations*

The Mueller bakery chiller system is designed to operate with R-22 (chlorodifluoromethane), a Class II HCFC refrigerant. R-22 refrigerant is specified by ASHRAE Standard 34 Safety Classification as an "A-1" refrigerant that represents low-flame propagation and low toxicity.

EPA regulations require that any technician performing refrigerant installation or service on a high pressure appliance be certified as a Type II Technician in accordance with Section 608 of the Clean Air Act.

**As adopted for the United States and Canada. These regulations may change or differ for your locality. It is the responsibility of the technician performing the refrigerant service and/or installation to abide by all regulatory requirements for the installation locality, state, and country.*

7.5 Thermal Expansion Valve (TEV) Superheat Adjustment

Take the following readings with the water storage tank full of water at a temperature below 40°F.

1. Take an accurate suction pressure at the evaporator outlet.

SERVICE NOTE: The suction pressure must be taken at the evaporator outlet rather than the suction-service valve due to unknown pressure drop in the refrigerant line between the evaporator and compressor (refer to Figure 8). The technician should also make certain that the system is charged with refrigerant as described in Section 2.0.

2. Utilizing an accurate electronic thermometer, take the actual suction line temperature near the TEV sensing bulb.

7.5 Thermal Expansion Valve (TEV) Superheat Adjustment (Continued)

- Utilizing an R-22 or R-507 Pressure Temperature Chart, convert the suction pressure reading from Step 1 to saturation temperature.
- The superheat value is found by subtracting the saturation temperature determined in Step 3 from the actual suction line temperature taken in Step 2.
- If the superheat is not in the range of 8 to 10°F, at conditions as described above, adjust the TEV.
- If the superheat is below 8°F, turn the TEV's adjustment stem clockwise $\frac{1}{8}$ to $\frac{1}{4}$ of a turn. Allow the system to operate for 5 minutes before repeating test.
- If the superheat is above 10°F, turn the TEV's adjustment stem counterclockwise $\frac{1}{8}$ to $\frac{1}{4}$ of a turn. Allow the system to operate for 5 minutes before repeating test.
- Any time adjustment is made to the TEV, the refrigerant charge should be checked.
- Check the superheat setting and make final adjustments at a product temperature near setpoint for best performance.

7.6 Thermal Expansion Valve Superheat Adjustment Diagram

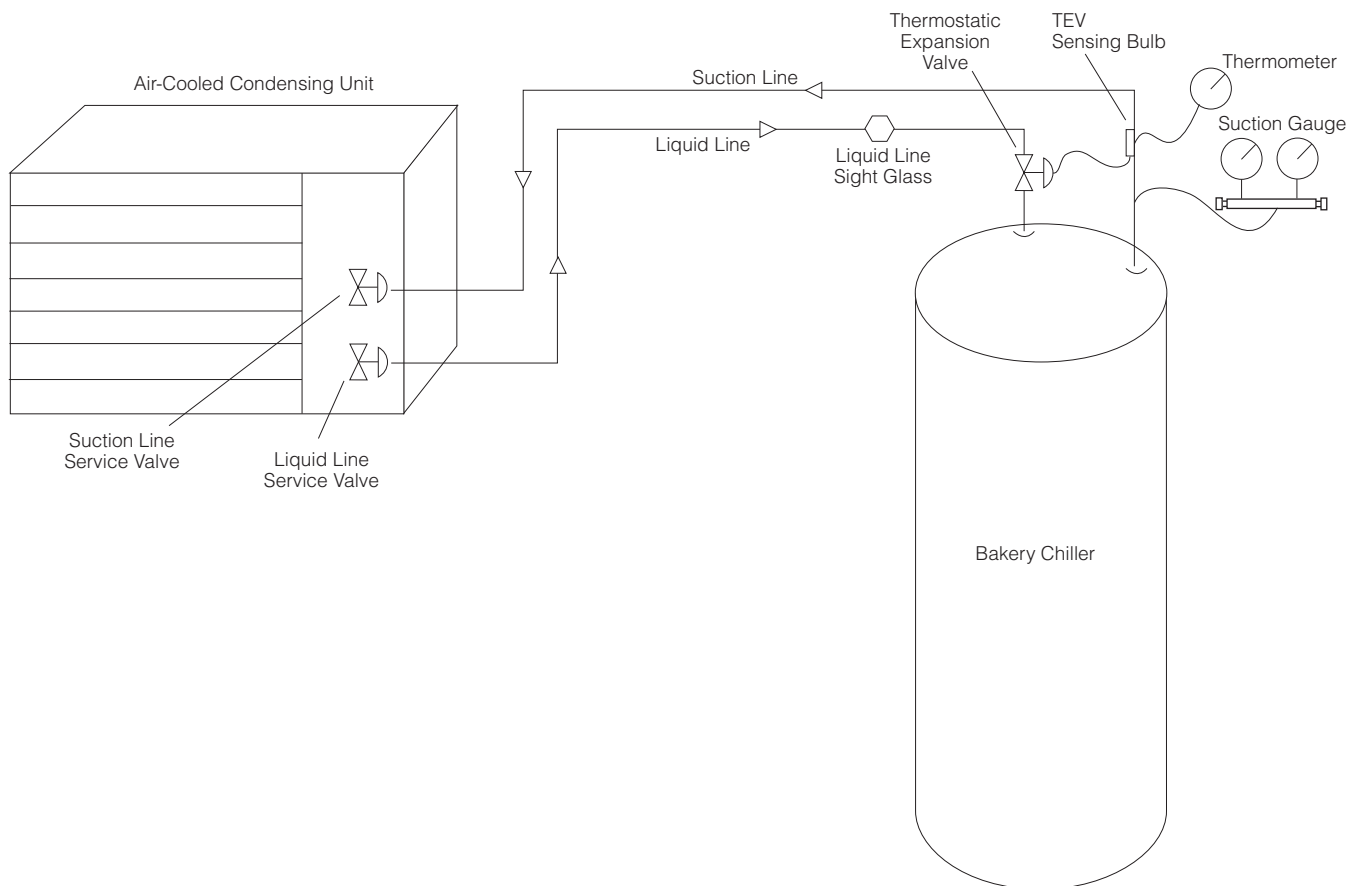

SECTION 8.0 - WARRANTY

WARRANTY

Mueller® Bakery Chiller

One Year Parts Warranty

The Paul Mueller Company (*hereafter referred to as Company*) will repair or (at the *Company's* option) replace any part or portion of a Mueller Bakery Chiller found to be defective in workmanship or material under normal use, service, and installation procedures, for a period of one (1) year from the date of installation by the original purchaser-user, or eighteen (18) months from the date of shipment from the *Company* factory, whichever occurs first. This warranty covers replacement of parts or repair of the equipment only. (See General Provisions).

Claim Procedures for One Year Parts Warranty

All defective parts covered by the one year parts warranty, must be returned to the *Company* with an attached Returned Goods Tag (Form O-209) and with transportation cost prepaid. Current instructions provided by the Refrigeration Products Department for return procedures must be followed to receive warranty.

Five-Year Structural Warranty

The *Company* warrants to the original purchaser-user that the Mueller Bakery Chiller evaporator (cooling plate) and water storage tank will remain free from defects in material and workmanship under normal use, service, and installation procedures for a period of five (5) years from the date if installed by the original purchaser-user or sixty-six (66) months from date of shipment from the *Company* factory, whichever comes first. Under this warranty, the *Company's* obligation shall be limited to the repair or, at the *Company's* option, the replacement of the Bakery Chiller evaporator or water tank. Damage caused by freezing is not covered by this warranty. (See General Provisions).

Claim Procedures for the Five-Year Warranty

A return authorization number must be obtained from the Paul Mueller Company's Refrigeration Products Department prior to returning a Mueller Bakery Chiller evaporator or water tank. Current instructions, provided by the Refrigeration Products Department for return procedures, must be followed to receive warranty.

General Provisions

Transportation and inspection cost incurred by the *Company* will be charged to the purchaser/user if returned material is not found to be defective. This warranty does not cover items such as refrigerant, mileage, product loss, cost of substitute storage facilities, parts and labor charged by others, or consumable items such as filter driers, rubber goods, or glass. The above will constitute the *Company's* total responsibility. The above Warranties will not apply in the event of abuse, misuse, negligence, improper installation procedures alterations by unauthorized service, damage by flood, fire, windstorm, lightning or acts of God. Oral statements made by employees' or representatives' of the *Company* will not constitute warranties. The above Warranties apply only to the original purchaser-user and original installation location and are not transferable.

This warranty is effective on Mueller Bakery Chillers purchased within the continental United States and Canada. Contact the Mueller International Sales Department for warranty provisions and policies outside of the continental United States and Canada.



Paul Mueller Company

P.O. Box 828 • Springfield, Missouri 65801-0828, U.S.A.

Phone: (417) 575-9000 • Fax: 1-800-436-2466

SECTION 9.0 - INSTALLATION AND SERVICE NOTES

Customer Name:

Dealer Name:

Address:

Address:

Telephone:

Telephone:

Quad Plate Chiller Model:

Serial No.:

Compressor Model:

Serial No.:

Date of Installation:

Notes:



P.O. Box 828 • Springfield, Missouri 65801-0828, U.S.A.
Phone: (417) 575-9000 • 1-800-MUELLER • Fax: 1-800-436-2466
www.muel.com • E-mail: refrigeration@muel.com