

# Mueller® Clamp-on Temp-Plate® Heat Transfer Surface

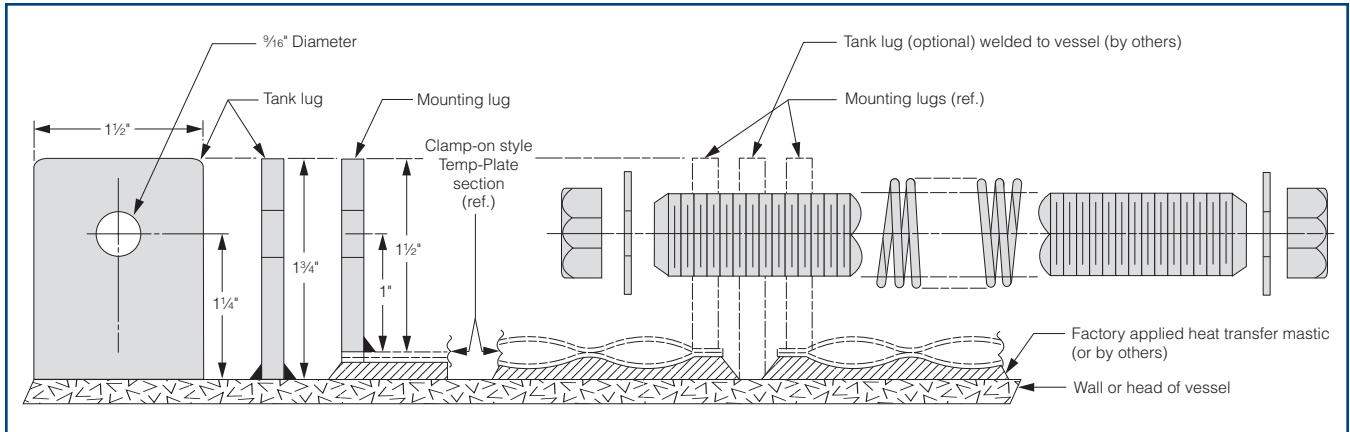

## Installation Guidelines for Factory Pre-Applied Mastic

1. Leaving the protective plastic cover on the Temp-Plate® panels, position the heat transfer panel and mark the locations for installation of the tank mounting lugs. These are shipped loose with the Temp-Plate sections. Refer to the sketch above for the typical arrangement. Allow approximately 1/2" between the tank lug and the lug on the Temp-Plate panels. This space will be taken up by the spring-loaded bolts used in the final steps.

2. Remove the Temp-Plate section. Weld the tank mounting lugs in position.
3. Remove the protective plastic cover from the panels.
4. Position the Temp-Plate section as previously located.

NOTE: Excess mastic will be allowed to flow out of the perimeter.

5. The spring-loaded bolt assemblies are used to allow for thermal expansion of the Temp-Plate sections. Place the spring on the outside of the Temp-Plate lug and tighten the nuts to near full compression. As the Temp-Plate section expands, the spring will relax and still maintain the proper fit. Refer to the sketch above.
6. The installation of the Temp-Plate heat transfer section is now complete. The plumbing connections are to be made next, using proper configurations to ensure efficient operation.

Refer to our *All About Temp-Plate* brochure (TP-108) for guidelines on plumbing methods.

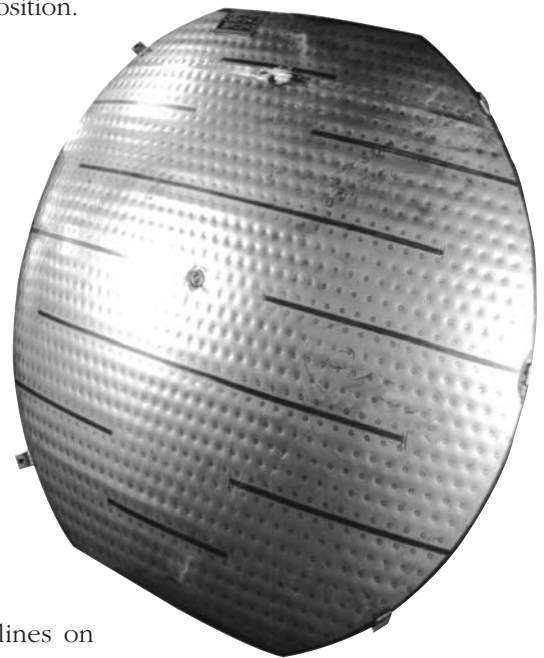

**MUELLER**®  
HEAT TRANSFER PRODUCTS

## Installation Guidelines for Field Applied Mastic

1. Position the heat transfer panels (without heat transfer mastic) and mark the locations for installation of the loose tank mounting lugs, shipped loose with the Temp-Plate® sections. Refer to the sketch on front for the typical arrangement. Allow approximately 1/2" between the tank lug and the Temp-Plate lug.
2. Remove the Temp-Plate section and weld the tank mounting lugs in position.
3. Install the heat transfer mastic to a uniform thickness of 1/16" – 1/8" on the interior surface of the Temp-Plate section.
4. Reinstall the Temp-Plate section as previously located. Excess mastic will be allowed to flow out of the perimeter.
5. The spring-loaded bolt assemblies are used to allow for thermal expansion of the Temp-Plate sections. Place the spring on the outside of the Temp-Plate lug and tighten the nuts to near full compression. As the Temp-Plate section expands, the spring will relax and still maintain the proper fit. Refer to the sketch above.
6. The installation of the Temp-Plate heat transfer section is now complete. The plumbing connections are to be made next, using proper configurations to ensure efficient operation.

Refer to our *All About Temp-Plate* brochure (TP-108) for guidelines on plumbing methods.

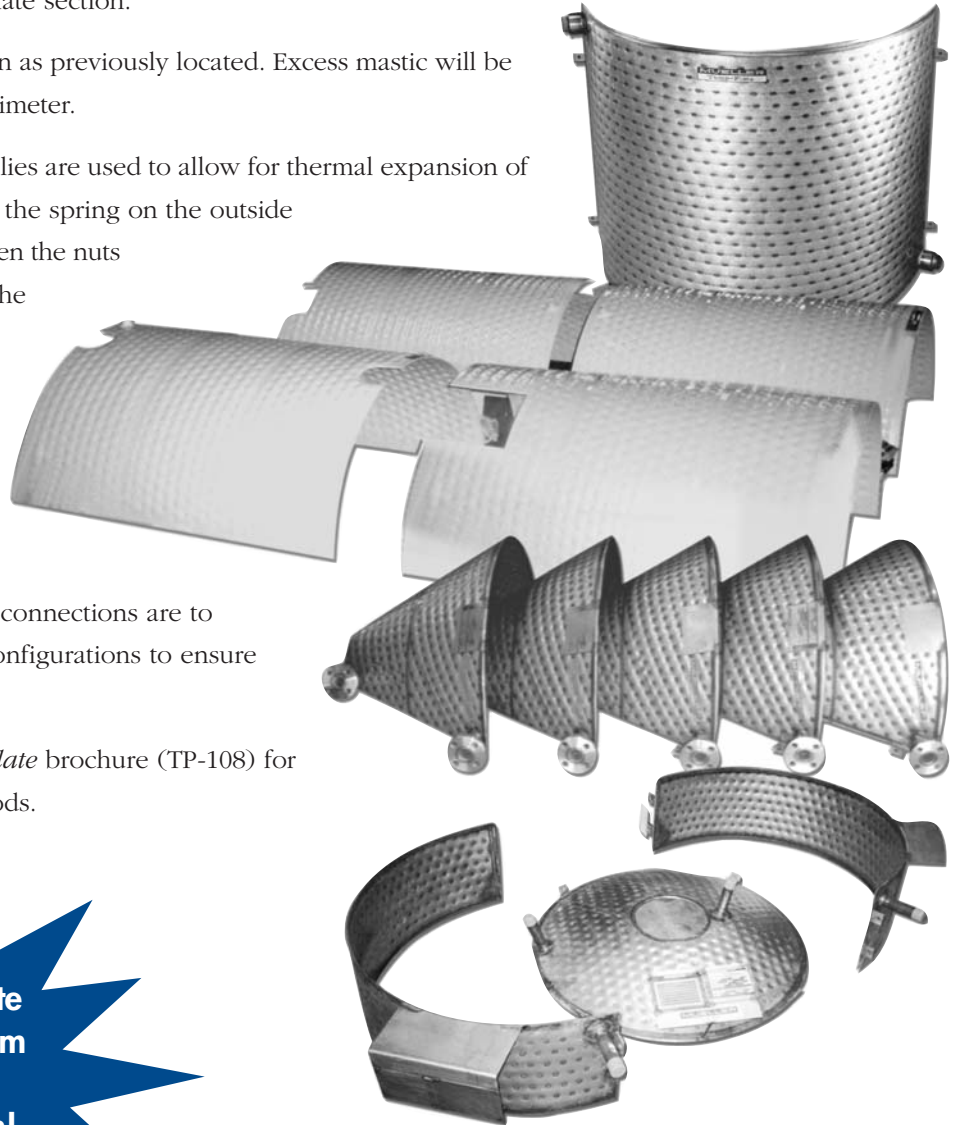

Visit our Web site  
at [www.hrx.com](http://www.hrx.com)  
for your heat  
transfer solution!

**MUELLER**®

P.O. Box 828 • Springfield, Missouri 65801-0828, U.S.A.  
Phone: (417) 575-9000 • 1-800-MUELLER • Fax: (417) 575-9885  
[www.muel.com](http://www.muel.com) • E-mail: [heattransfer@muel.com](mailto:heattransfer@muel.com)