

MaximICE®



MUELLER[®]
THERMAL ENERGY STORAGE

Mueller® MaximICE®

Techno-Mart 21 Complex in Seoul, Korea

The “Techno-Mart 21” complex is one of the largest commercial buildings in Korea, housing a 10-story merchandise mart and a 39-story office tower with a total area of approximately 2.8 million square feet (260,100 square meters).

The Mueller® MaximICE® ice slurry thermal energy storage system offered a reduction of \$524,000 in annual operating costs and an incremental payback of 1.1 years compared to the conventional system.

The 4,000-ton (14,068 kW) thermal energy storage system consists of eight 500-ton (1,759 kW) MaximICE ice slurry generators.



MaxiMICE ICE SLURRY SYSTEM

The major components of the MaxiMICE ice slurry system are shown below in the system schematic.

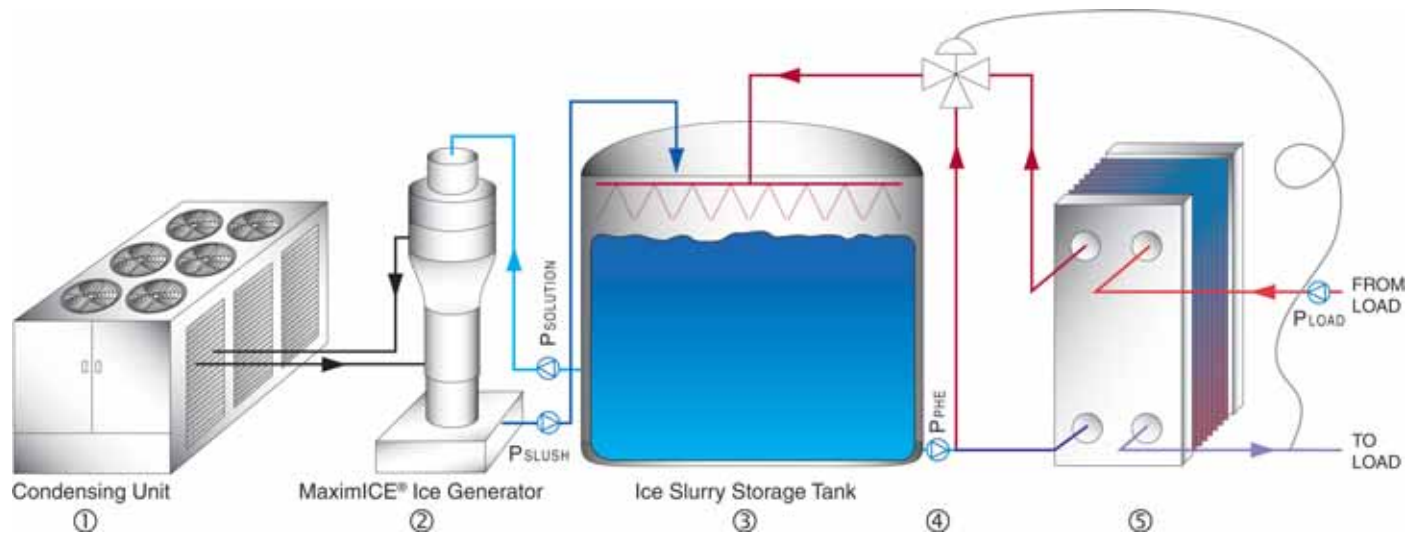

1. **Compressor/condenser** supplies refrigerant to the evaporator.
 2. **MaximICE orbital rod evaporator (ORE)** uses a freeze-depressant solution to produce a pumpable ice slurry. Low-temperature slurry makes MaximICE ideal for use with low-temperature air systems.
 3. **Insulated ice storage tank** separates ice manufacturing from ice usage. The tank contains a freeze-depressant solution which is converted to an ice slurry in the MaximICE evaporator. The slurry melts as the stored ice absorbs the heat of the cooling load.
 4. **Load control pump and valve controls** the supply temperature to the load.
 5. **Plate heat exchanger** separates the storage tank from the cooling load and prevents cross contamination between the ice-melting loop and the cooling load.
- Project load** defined by client.
- Note:** Solution can be supplied from the ice storage tank to the load at various temperatures to satisfy specific application needs. Consult Paul Mueller Company for details.

MaximICE TES Process Description

Freeze-depressant solution stored in the tank enters the top of the MaximICE ice slurry generator and gravity drains through the tube side. Liquid refrigerant from the condensing unit enters the shell side of the evaporator and removes heat from the solution. As heat is removed, some of the water is frozen out of the solution resulting in ice slurry which can either drain into the tank or be pumped to the top of the storage tank. Low-temperature solution from the bottom of the tank cools the load as needed. The warm solution returning from the cooling load is sprayed on the ice stored in the tank by one or more spray nozzles evenly spaced to cover the ice surface. In the storage tank, the warm solution cools by direct contact as the stored ice absorbs heat and provides a low-temperature heat sink to the cooling load.



*ORE-400
(pumped overfeed)*

Note: Normally, a plate heat exchanger will isolate the storage tank from the cooling load.

Advantages of MaximICE Ice Slurry System

Higher energy efficiency. Unlike static ice systems where ice adheres to the heat transfer surface, ice slurry produced by the MaximICE ice slurry generator does not adhere to any heat transfer surface, resulting in higher energy efficiency. Unlike ice harvesters, defrost is not required to harvest the ice for storage into tanks, resulting in higher energy efficiency.

Cost-effective tank design. Ice slurry can be pumped into storage tanks, reducing the need for extra structural support required for ice harvesters located above the storage tanks.

Flexible ice storage tank design. Ice slurry can be stored in tanks of any shape. For example, the height of an ice storage tank can be increased, resulting in a reduction of the tank footprint which leads to valuable floor space savings. This is difficult to achieve in static and other dynamic ice storage systems.

Compact equipment. Small evaporator footprint offers space savings in the refrigeration equipment room.

Lower supply temperature. System offers lower supply water temperature versus other ice systems.

Maintenance-free ice tank design. Unlike ice-on-coil systems, ice slurry systems do not require miles of pipe or tubing in the storage tanks. This eliminates the need for repairing leaking pipes or tubing inside the tank.

Satisfies large loads. Large loads for short durations can be met by ice slurry systems due to the quick melting of ice which is achieved by a large area of contact between the warm return solution and stored ice.

Ease of modification. System can be easily adapted to changing needs. For example, facility expansion may occur and facility use and/or utility rates may change.

Thermal Energy Storage Systems

Thermal energy storage (TES) systems typically involve the production of ice or chilled water during off-peak electrical usage periods (usually at night) using lower cost electricity. This stored energy is then used during on-peak electrical usage periods for air conditioning or process cooling.

Thermal energy storage systems can be sized to operate in a load-shifting or load-leveling strategy. In a load-shifting strategy, the TES system runs during off-peak hours, eliminating electrical demand charges and reducing energy costs. In a load-leveling strategy, equipment is allowed to operate 24 hours a day.

Smaller equipment capacity. Compared to traditional cooling systems, TES systems utilize smaller equipment capacity and typically operate during off-peak hours, reducing operating costs.

Smaller capital costs. TES systems occasionally provide savings in initial capital costs versus traditional cooling systems.

Energy savings. Thermal energy storage systems provide energy savings when there are high loads of short duration, high electric power demand charges, or low electrical charges during off-peak hours.

TRADITIONAL COOLING SYSTEMS

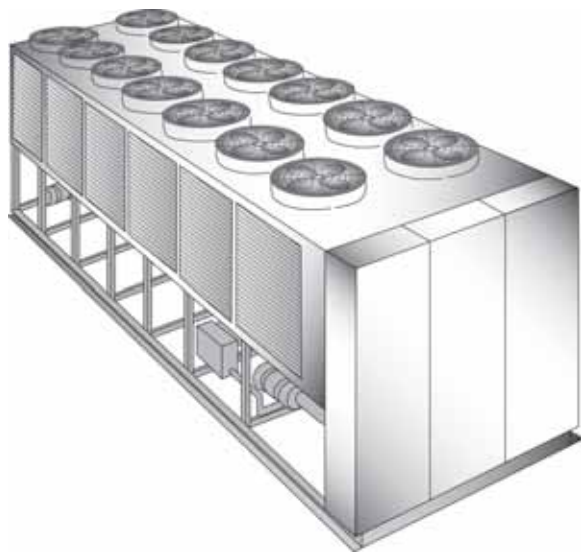

- ◆ Larger equipment capacity required
- ◆ Higher operating costs
- ◆ Occasionally higher initial capital costs on batch applications

MAXIMICE ICE SLURRY COOLING SYSTEMS

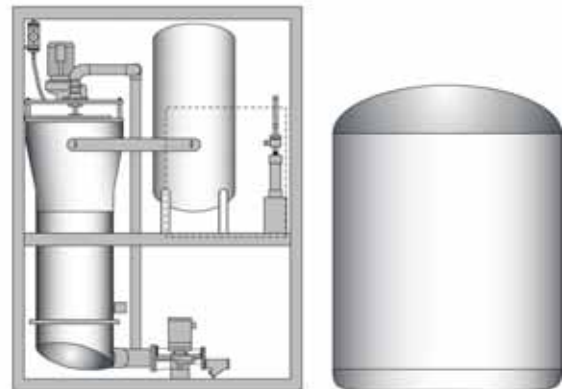

- ◆ Smaller equipment capacity required
- ◆ Additional storage tank
- ◆ Lower operating costs
- ◆ Shorter payback compared to conventional cooling systems
- ◆ Potentially lower initial capital costs

Example of Thermal Energy Storage

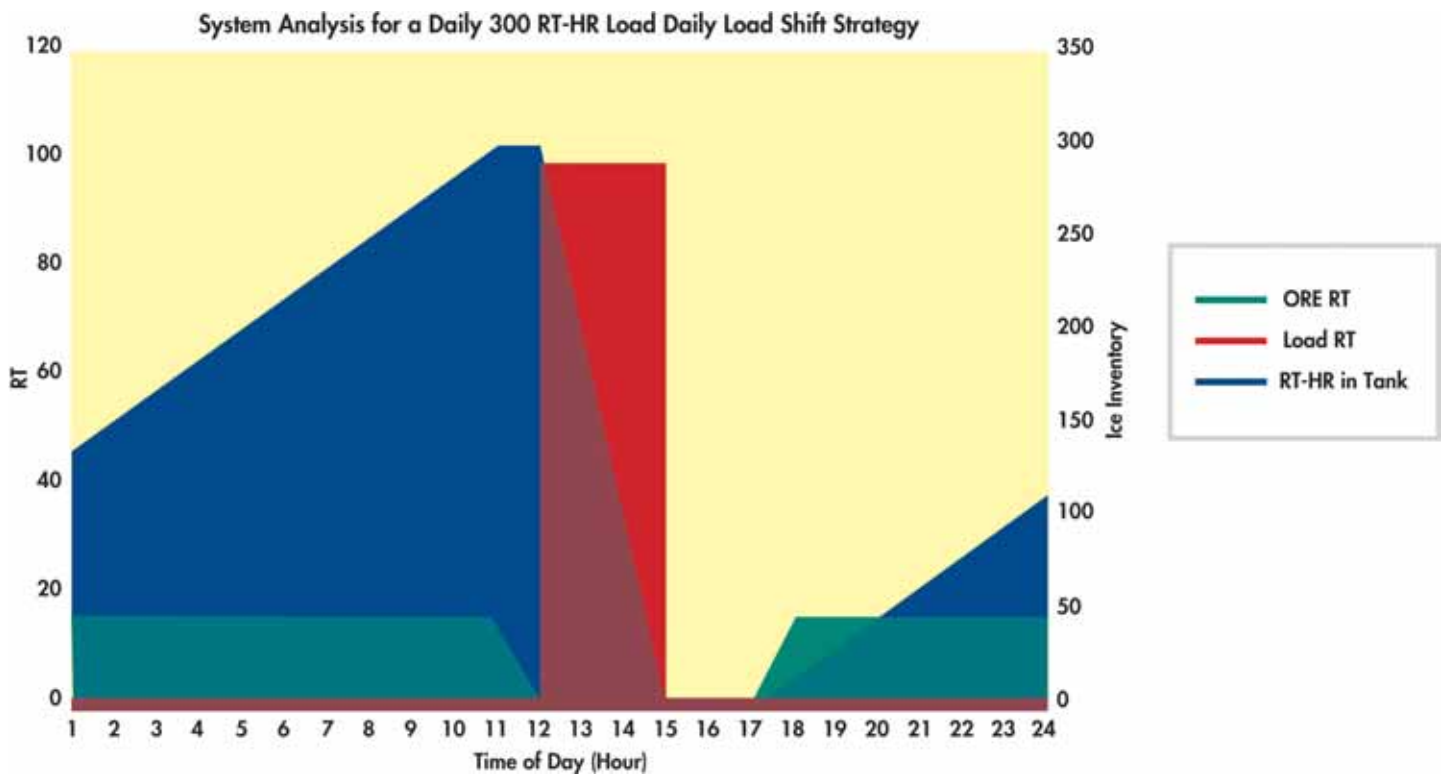

Typical Process Load

100 RT (refrigeration ton) load for a duration of three hours per day (300 RT-HR), 365 days a year.

Utility Rate Structure

Off-peak period	5 p.m. - 11 a.m.
Off-peak energy rate (U.S. \$/kWh)	0.03
On-peak period	11 a.m. - 5 p.m.
On-peak energy rate (U.S. \$/kWh)	0.08
On-peak demand (U.S. \$/kW)	12.50

Conventional Cooling System

A 100 RT peak load conventional cooling system is required to achieve this cooling duty.

Mueller MaximICE TES System

A 16.7 RT Mueller MaximICE TES system, with an ice storage tank operating during off-peak hours, will satisfy the cooling duty.

TES System Advantage

TES system provides savings in initial capital costs (16.7 RT TES equipment versus 100 RT chiller). A \$19,800* savings in annual operating costs are obtained by using the 16.7 RT Mueller MaximICE TES system versus a conventional chiller system.

**Operating cost savings are based on MaximICE kW/RT of 1.2, air-cooled chiller kW/RT of 1.0 (EER=12), utility rates shown above, and TES equipment operated on a daily shift strategy.*

Mueller MaximICE

MaximICE Typical Applications

- ◆ *Comfort cooling* of office buildings, hotels, churches, schools, auditoriums, and sports arenas.
- ◆ *District cooling.*
- ◆ *Gas turbine inlet air cooling.*
- ◆ *Processing equipment cooling* for food processing, dairies, breweries, and packaged ice for cooling fresh produce.

Optional Accessories

Refrigerants. ORE units use common refrigerants, such as R-22 and R-717. Consult Paul Mueller Company for details.

Ice Outlet Arrangement. Ice slurry is free flowing and may be discharged either by draining directly into the ice storage tank (gravity discharge) or by pumping it into the ice storage tank (pumped discharge). Pumped ice outlet arrangement reduces head room and extra structural support for the ice storage tank since the ORE unit is not located on top of the tank.

Cabinet. Units can be completely enclosed in a specially designed weather-protection cabinet suitable either for “mild” or “winter” weather protection.

Packaging. Unit can either be shrink wrapped or fully crated for overseas shipment in order to minimize possible shipping damage.

Equipment Sizes

MaximICE units are offered in seven standard sizes. Multiple units can be combined for larger capacities or system redundancy.

MODEL	CAPACITY WITH REFRIGERANT R-22 TONS (KW)
ORE-3	3 (11)
ORE-25	15 to 33 (53 to 116)
ORE-50	35 to 65 (123 to 229)
ORE-100	70 to 130 (246 to 457)
ORE-200	140 to 260 (492 to 914)
ORE-300	265 to 390 (932 to 1372)
ORE-400	400 to 520 (1407 to 1829)

These units are also compatible for use with R-717 refrigerant (except ORE-3).

Full-Ice Condition Sensor. A temperature sensor detects full-ice condition through an increase in freeze-point depression. This sensor can either be mounted inside the control panel or shipped loose for remote field mounting. The unit may also be ordered without the temperature sensor for field supply by others.

Power Supply. Several choices of electrical power supply are available. Refer to the electrical data sheet for available options.

English Message Display Panel. Message display in words rather than code numbers allows easy access to operating data.



ORE-25

ORE-50 BACK VIEW

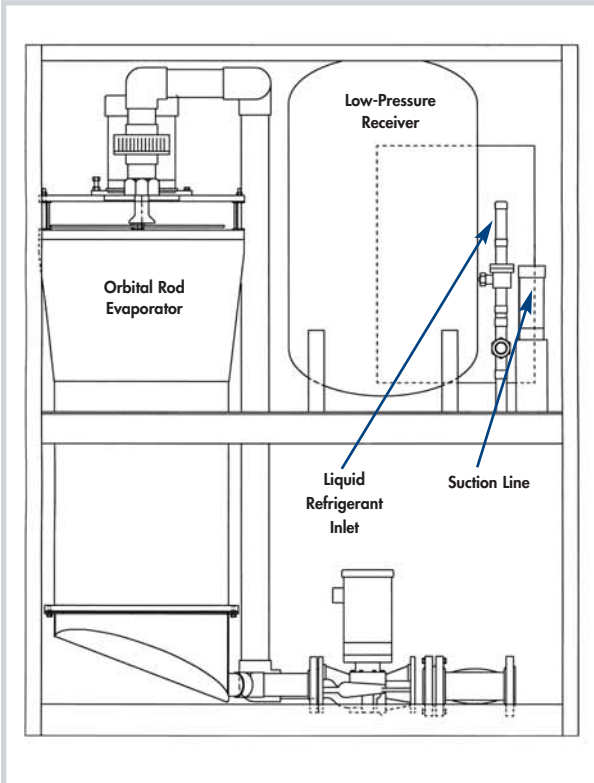

ORE-50 SIDE VIEW

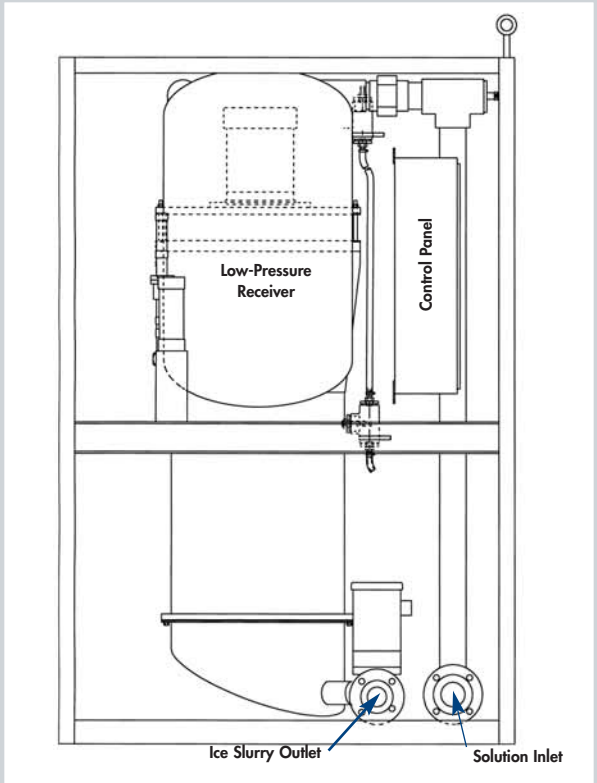

ORE-200* BACK VIEW

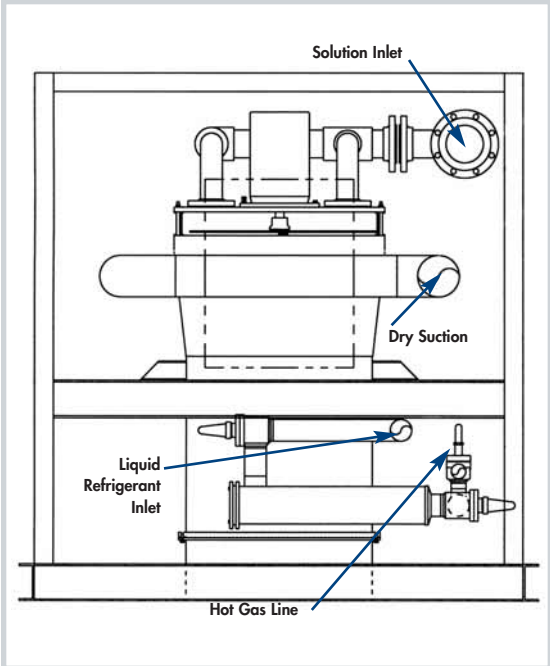

ORE-200* SIDE VIEW

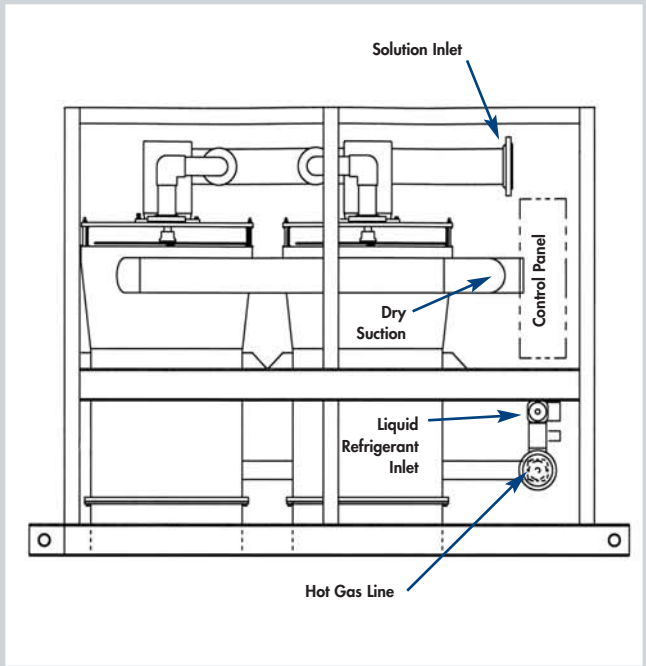

**Pumped overfeed.*

Drawings are for reference only. Contact Paul Mueller Company for drawings on the entire product line.

Mueller MaximICE

Physical Data

Data	MaximICE Model			
	ORE-3	ORE-25	ORE-50	ORE-100
Type of Refrigerant Feed	FLOODED			
Unit with Refrigerant R-22				
Refrigerant Charge, R-22, lbs. (kg)	28 (13)	250 (113)	600 (272)	1250 (567)
Suction Conn., Inches (ODS or OD x wall thickness, mm)	1 ^{3/8} " (34.9) ODS	2 ^{5/8} " (66.7) ODS	3 ^{1/8} " (79.4) ODS	4 ^{1/8} " (104.8) ODS
Liquid Conn., Inches (ODS or OD x wall thickness, mm)	5/8" (15.9) ODS	1 ^{1/8} " (28.6) ODS	1 ^{3/8} " (34.9) ODS	1 ^{5/8} " (41.3) ODS
Unit with Refrigerant R-717				
Refrigerant Charge, R-717, lbs. (kg)	N/A	125 (57)	300 (136)	625 (284)
Suction Conn., Inches (ODS or OD x wall thickness, mm)	N/A	2" SCH 40 (60.3 x 3.9)	2 ^{1/2} " SCH 40 (73.0 x 5.2)	3 ^{1/2} " SCH 40 (101.6 x 5.7)
Liquid Conn., Inches (ODS or OD x wall thickness, mm)	N/A	3/4" SCH 80 (26.7 x 3.9)	1" SCH 80 (33.4 x 4.5)	1 ^{1/4} " SCH 80 (42.2 x 4.9)
Unit with Gravity Ice Outlet Arrangement				
Unit Dimensions, L x W x H, inches	N/A	58 x 46 x 87	70 x 58 x 87	94 x 78 x 96
Unit Dimensions, L x W x H, mm	N/A	1473 x 1168 x 2210	1778 x 1473 x 2210	2388 x 1981 x 2438
Unit Ship Weight, lbs. (kg)	N/A	2450 (1111)	3700 (1678)	5915 (2683)
Unit Design Weight, lbs. (kg)	N/A	2700 (1225)	4200 (1905)	6915 (3137)
Unit with Pumped Ice Outlet Arrangement				
Unit Dimensions, L x W x H, inches	30 x 18 ^{3/4} x 66	58 x 46 x 87	70 x 58 x 87	94 x 78 x 96
Unit Dimensions, L x W x H, mm	762 x 476 x 1676	1473 x 1168 x 2210	1178 x 1473 x 2210	2388 x 1981 x 2439
Unit Ship Weight, lbs. (kg)	280 (127)	2500 (1134)	3900 (1769)	6015 (2728)
Unit Design Weight, lbs. (kg)	305 (138)	2750 (1247)	4400 (1996)	7015 (3182)
Slush Pump Discharge Head, 60 hz/50 hz, ft (meters)				
Number of Slush Pumps per Unit	1	1	1	1
Pump Size - 1/7 hp	18/18 (5.5/5.5)	N/A	N/A	N/A
Pump Size - 3/4 hp	N/A	22/14 (6.7/4.3)	N/A	N/A
Pump Size - 2 hp	N/A	49/31 (14.9/9.5)	29/15 (8.8/4.6)	N/A
Pump Size - 3 hp	N/A	N/A	47/21 (14.3/6.4)	30/21 (9.1/6.4)
Pump Size - 5 hp	N/A	N/A	N/A	38/24 (11.6/7.3)
Pump Size - 7.5 hp	N/A	N/A	N/A	79/44 (24.1/13.4)
Pump Size - 10 hp	N/A	N/A	N/A	97/59 (29.6/18.0)
Solution Feed to ORE Unit				
Total Unit Flow Rate, gpm (lps)	9 (0.57)	65 (4.10)	135 (8.52)	245 (15.46)
Number of Evaporators per Unit	1	1	1	1
Flow Rate per Evaporator, gpm (lps)	9 (0.57)	65 (4.10)	135 (8.52)	245 (15.46)
Required Inlet Pressure, psig (kPa)	N/A	5 to 30 (35 to 207)	5 to 30 (35 to 207)	5 to 30 (35 to 207)

Notes:

1. ORE-3 is not available with refrigerant R-717.
2. ORE-3 includes standard 1/7 hp solution pump and 1/7 hp slush pump. Solution pump is suitable for 9 gpm (0.57 lps) and 18 feet (5.5 meters) discharge head.
3. ORE-3 must be used with a PMC factory-supplied condensing unit.

Physical Data

Data	MaximICE Model		
	ORE-200	ORE-300	ORE-400
Type of Refrigerant Feed	PUMPED OVERFEED		
Unit with Refrigerant R-22			
Refrigerant Charge, R-22, lbs. (kg), (for evaporator only)	1400 (635)	2100 (953)	2800 (1270)
Suction Conn., Inches (ODS or OD x wall thickness, mm)	6" SCH 40 (168.3 x 7.1)	10" SCH 40 (273.1 x 9.3)	10" SCH 40 (273.1 x 9.3)
Liquid Conn., Inches (ODS or OD x wall thickness, mm)	2 ^{1/2} " SCH 40 (73.0 x 5.2)	3" SCH 40 (88.9 x 5.5)	3" SCH 40 (88.9 x 5.5)
Unit with Refrigerant R-717			
Refrigerant Charge, R-717, lbs. (kg)	700 (318)	1050 (476)	1400 (635)
Suction Conn., Inches (ODS or OD x wall thickness, mm)	6" SCH 40 (168.3 x 7.1)	10" SCH 40 (273.1 x 9.3)	10" SCH 40 (273.1 x 9.3)
Liquid Conn., Inches (ODS or OD x wall thickness, mm)	2 ^{1/2} " SCH 40 (73.0 x 5.2)	3" SCH 40 (88.9 X 5.5)	3" SCH 40 (88.9 X 5.5)
Unit with Gravity Ice Outlet Arrangement			
Unit Dimensions, L x W x H, inches	120 x 84 x 84 ^{1/2}	161 ^{3/4} x 84 x 84 ^{1/2}	202 x 84 x 84 ^{1/2}
Unit Dimensions, L x W x H, mm	3048 x 2134 x 2146	4109 x 2134 x 2146	5131 x 2134 x 2146
Unit Ship Weight, lbs. (kg)	8200 (3719)	12,300 (5579)	16,400 (7439)
Unit Design Weight, lbs. (kg)	10,350 (4694)	15,500 (7030)	21,800 (9888)
Unit with Pumped Ice Outlet Arrangement			
Unit Dimensions, L x W x H, inches	120 x 88 x 94	161 ^{3/4} x 88 x 94	202 x 88 x 94
Unit Dimensions, L x W x H, mm	3048 x 2235 x 2388	4109 x 2235 x 2388	5131 x 2235 x 2388
Unit Ship Weight, lbs. (kg)	8400 (3810)	12,600 (5715)	16,400 (7438)
Unit Design Weight, lbs. (kg)	10,550 (4785)	15,800 (7167)	21,800 (9889)
Slush Pump Discharge Head, 60 hz/50 hz, ft (meters)			
Number of Slush Pumps per Unit	2	3	4
Pump Size - 1/2 hp	N/A	N/A	N/A
Pump Slze - 3/4 hp	N/A	N/A	N/A
Pump Slze - 2 hp	N/A	N/A	N/A
Pump Size - 3 hp	30/21 (9.1/6.4)	30/21 (9.1/6.4)	30/21 (9.1/6.4)
Pump Slze - 5 hp	38/24 (11.6/7.3)	38/24 (11.6/7.3)	38/24 (11.6/7.3)
Pump Size - 7.5 hp	79/44 (24.1/13.4)	79/44 (24.1/13.4)	79/44 (24.1/13.4)
Pump Slze - 10 hp	97/59 (29.6/18.0)	97/59 (29.6/18.0)	97/59 (29.6/18.0)
Solution Feed to ORE Unit			
Total Unit Flow Rate, gpm (lps)	490 (30.91)	735 (46.37)	980 (61.83)
Number of Evaporators per Unit	2	3	4
Flow Rate per Evaporator, gpm (lps)	245 (15.46)	245 (15.46)	245 (15.46)
Required Inlet Pressure, psig (kPa)	5 to 30 (35 to 207)	5 to 30 (35 to 207)	5 to 30 (35 to 207)

Mueller MaximICE

Physical Data - XL Models

Data	MaximICE Model		
	ORE-200 XL	ORE-300 XL	ORE-400 XL
Type of Refrigerant Feed	GRAVITY		
Unit with Refrigerant R-22			
Refrigerant Charge, R-22, lbs (kg), (for evaporator only)	1,550 (635)	2,100 (953)	3,000 (1,270)
Suction Connection, Inches (ODS or OD x wall thickness, mm)	6" SCH 40 (168.3 x 7.1)	10" SCH 40 (273.1 x 9.3)	10" SCH 40 (273.1 x 9.3)
Liquid Connection, Inches (ODS or OD x wall thickness, mm)	2 1/2" SCH 40 (73.0 x 5.2)	3" SCH 40 (88.9 x 5.5)	3" SCH 40 (88.9 x 5.5)
Unit with Refrigerant R-717			
Refrigerant Charge, R-717, lbs (kg)	775 (351)	1,050 (477)	1,500 (680)
Suction Connection, Inches (ODS or OD x wall thickness, mm)	6" SCH 40 (168.3 x 7.1)	10" SCH 40 (273.1 x 9.3)	10" SCH 40 (273.1 x 9.3)
Liquid Connection, Inches (ODS or OD x wall thickness, mm)	2 1/2" SCH 40 (73.0 x 5.2)	3" SCH 40 (88.9 X 5.5)	3" SCH 40 (88.9 X 5.5)
Unit with Gravity Ice Outlet Arrangement			
Unit Dimensions, L x W x H, inches	170 x 90 x 92	223 x 90 x 935/8	2647/8 x 92 x 107
Unit Dimensions, L x W x H, mm	4,318 x 2,286 x 2,336.8	5,664.2 x 2,286 x 2,387.6	6,731 x 2,336.8 x 2,717.8
Unit Ship Weight, lbs (kg)	15,850 (7,189.4)	23,307 (10,571)	27,350 (12,406)
Unit Design Weight, lbs (kg)	19,350 (8,777)	25,300 (11,476)	35,000 (15,876)
Unit with Pumped Ice Outlet Arrangement			
Unit Dimensions, L x W x H, inches	170 x 90 x 92	223 x 90 x 935/8	2647/8 x 92 x 107
Unit Dimensions, L x W x H, mm	4,318 x 2,286 x 2,337	5,664 x 2,286 x 2,337	6,731 x 2,336.8 x 2,717.8
Unit Ship Weight, lbs (kg)	17,250 (7,824.4)	23,307 (10,572)	27,560 (12,501)
Unit Design Weight, lbs (kg)	19,350 (8,777)	25,300 (11,476)	30,760 (13,952)
Slush Pump Discharge Head, 60 hz/50 hz, ft (meters)			
Number of Slush Pumps per Unit	2	3	4
Pump Size - 1/7 hp	N/A	N/A	N/A
Pump Slze - 3/4 hp	N/A	N/A	N/A
Pump Slze - 2 hp	N/A	N/A	N/A
Pump Size - 3 hp	30/21 (9.1/6.4)	30/21 (9.1/6.4)	30/21 (9.1/6.4)
Pump Slze - 5 hp	38/24 (11.6/7.3)	38/24 (11.6/7.3)	38/24 (11.6/7.3)
Pump Size - 7.5 hp	79/44 (24.1/13.4)	79/44 (24.1/13.4)	79/44 (24.1/13.4)
Pump Slze - 10 hp	97/59 (29.6/18.0)	97/59 (29.6/18.0)	97/59 (29.6/18.0)
Solution Feed to ORE Unit			
Total Unit Flow Rate, gpm (lps)	490 (30.91)	735 (46.37)	980 (61.83)
Number of Evaporators per Unit	2	3	4
Flow Rate per Evaporator, gpm (lps)	245 (15.46)	245 (15.46)	245 (15.46)
Required Inlet Pressure, psid (kPa)	10 to 20 (69 to 138)	10 to 20 (69 to 138)	10 to 20 (69 to 138)

Typical MaximICE Installations Worldwide



Four ORE-300XL units and one ORE-400XL unit provide partial cooling for this multi-purpose business complex in Seoul, South Korea.



Korea International Exhibition Center in South Korea is cooled with four ORE-300XL units.



Shopping complex in Germany cooled by an ORE-50 unit.



ORE-100 units installed at a dairy processing plant in Japan. The use of a silo ice-storage tank saves expensive land.



An ORE-100 is used to produce packaged ice that is injected into boxes of broccoli for cooling during transportation.

SPRINGFIELD, MISSOURI



OSCEOLA, IOWA

MUELLER®

P.O. Box 828 • Springfield, Missouri, 65801-0828, U.S.A.
Phone: (417) 831-3000 • 1-800-MUELLER • Fax: (417) 831-6906
www.muel.com • E-mail: thermal@muel.com

©1998-2005 Paul Mueller Company



TE-2030-2